

**R. H. CUSHMAN**

University of Calgary  
2500 University Drive NW Calgary, Alberta, Canada T2N1N4

Mathematisch Instituut, Universiteit Utrecht  
P.O. Box 80 010, 3508 TA Utrecht, The Netherlands

E-mails: [cushman@math.ucalgary.ca](mailto:cushman@math.ucalgary.ca)  
[cushman@math.uu.nl](mailto:cushman@math.uu.nl)



**J. J. DUISTERMAAT\***

Mathematisch Instituut, Universiteit Utrecht  
P.O. Box 80 010, 3508 TA Utrecht, The Netherlands  
E-mail: [duis@math.uu.nl](mailto:duis@math.uu.nl)

# NEARLY FLAT FALLING MOTIONS OF THE ROLLING DISK

*Received July 17, 2005; accepted January 27, 2006*

DOI: 10.1070/RD2006v011n01ABEH000333

---

We study the motion of a disk which rolls on a horizontal plane under the influence of gravity, without slipping or loss of energy due to friction. There is a codimension one semi-analytic subset  $F$  of the phase space such that the disk falls flat in a finite time, if and only if its initial phase point belongs to  $F$ . We describe the motion of the disk when it starts at a point  $p \notin F$  which is close to a point  $f \in F$ . It then almost falls flat, after which it rises up again. We prove that during the short time interval that the disk is almost flat, the point of contact races around the rim of the disk from a well-defined position at the end of falling to a well-defined position at the beginning of rising, where the increase of the angle only depends on the mass distribution of the disk and the radius of the rim. The sign of the increase of the angle depends on the side of  $F$  from which  $p$  approaches  $f$ .

---

## Contents

1. Introduction and summary . . . . .	32
2. Set up . . . . .	33
2.1. The unconstrained disk . . . . .	33
2.2. The phase space of the rolling disk . . . . .	34
2.3. The equations of motion . . . . .	35
2.4. Reconstruction . . . . .	36
3. A potential function on an interval . . . . .	38
3.1. Chaplygin's equations . . . . .	38
3.2. A conservative system in one degree of freedom . . . . .	39
3.3. The motion of the angle $\varphi$ . . . . .	40
3.4. A special case of falling flat . . . . .	41
4. Scaling . . . . .	42
5. The solutions of Chaplygin's equations . . . . .	43
5.1. A recessive solution . . . . .	43
5.2. The general solution . . . . .	44

---

Mathematics Subject Classification: 70E18, 70E40, 70F25, 37J15, 37J60

Key words and phrases: nonholonomic systems, rolling disk, nearly falling flat

\* Research stimulated by a KNAW professorship.

6. Falling flat . . . . .	45
6.1. When it does not fall flat . . . . .	46
6.2. When it falls flat . . . . .	47
6.3. Limiting behaviour when falling flat . . . . .	48
7. Near falling flat . . . . .	49
7.1. Elastic reflection of the angle $\varphi$ . . . . .	50
7.2. The increase of the angles $\psi$ and $\chi$ . . . . .	51
7.3. Motions near falling flat . . . . .	53
References . . . . .	59

## 1. Introduction and summary

In this paper we consider a rolling disk as a body of revolution rolling on a horizontal plane under the influence of a constant vertical gravitational field. It rolls on a sharp rim on the body, which is a circle with center at the center of mass of the body. We also assume that the lowest point of the rim remains attached to the horizontal plane. This prevents the disk from taking off into space and continuing with a bouncing motion. We finally assume that there is no loss of energy due to friction.

Already Korteweg [11] indicated the existence of a large set of initial points in the phase space, the position-velocity space, for which the disk falls flat in a finite time. According to Borisov, Mamaev and Kilin [3], Kolesnikov [9] proved that the set of initial phase points which lead to the disk falling flat has zero measure. Fedorov [8] presented necessary and sufficient conditions for the disk to fall flat, that is, he described a codimension one semi-analytic subset  $F$  of the phase space such that the disk falls flat in a finite time if and only if its initial phase point belongs to  $F$ . Independently this has also been obtained by O'Reilly [13]-Sec. 5, where we found the reference to Korteweg [11].

We observe that, at the moment of becoming flat, the position of the disk, the point of contact, and the velocity of the disk all have a well defined limit. At the moment of becoming flat the disk performs a rotation about an axis through the limiting point of contact. The axis lies in the vertical plane which is tangent to the rim of the disk, but is not vertical itself. Because the limiting angular velocity is nonzero, the disk falls flat with a bang.

In this paper we show, by means of an asymptotic calculation, the following facts about the motions of rolling disks which nearly fall flat. If the initial data approach a point  $f \in F$  from one side of  $F$ , then, after the disk has almost fallen flat with the limiting point of contact  $p_-$ , in an arbitrarily small interval of time the point of contact races around the rim to a new position  $p_+$ . When it almost falls flat and rises from almost flat, the disk performs a rotation about an axis through  $p_-$  and  $p_+$ , as if it has fallen flat and risen from flat with the limiting point of contact at  $p_-$  and  $p_+$ , respectively. When going from almost falling flat to rising from almost flat, the nonzero time derivative of the angle of the disk with the horizontal plane changes its sign, as in an elastic reflection. While the point of contact races along the rim, it has an angular increase which is equal to a number  $\alpha$  which only depends on the mass distribution of the disk. For a hoop, where all the mass is on the rim, we have  $\alpha = \sqrt{3}\pi$ , whereas for a disk with a uniform mass distribution we have  $\alpha = \sqrt{5}\pi$ . In general  $\alpha = (1 + mr^2/I_1)^{1/2}\pi$ , where  $m$ ,  $r$ , and  $I_1$  are the total mass of the disk, the radius of the rim, and the moment of inertia about any axis in the plane of the rim, respectively. If the initial data approach  $f \in F$  from the other side of  $F$ , then the point of contact races around the rim in the opposite direction, and the angular increase  $\alpha$  has to be replaced by  $-\alpha$ .

In the complement of  $F$ , the motion of the rolling disk is given by a globally defined flow. When approaching  $F$  from one side, this flow has a limit motion on  $F$ , which extends the falling motion to all times. The limits, when approaching  $F$  from both sides, are the same if and only if  $mr^2/I_1 = l^2 - 1$  for some integer  $l$ . In particular these two limiting motions of the disk differ in the case of the uniform disk and the hoop. This destroyed our initial naive hope that there would be a well-defined continuation of the falling motion as the limits of the non-falling motions.

The plan of the paper is as follows. In Section 2, we describe the equations of motions, which lead to an integrable system for the equations in the reduced phase space, the phase space modulo the symmetries of the horizontal motion group in the space coordinates and the circular symmetry in the body coordinates. We also describe the reconstruction of the full motion from the solutions of the reduced system. This is essential for our proof of the asymptotic behaviour of the nearly flat falling disk. Section 2 also serves to introduce the notations. In Section 3 we introduce the description of the solutions of the reduced system in terms of an amended potential function, which was used earlier by Fedorov [8], O'Reilly [13], and Cushman, Hermans and Kemppainen [5]. In Section 4, we introduce a scaling in order to simplify the asymptotic formulae, and in Section 5 we collect some asymptotic formulas for the functions which appear in the amended potential. In Section 6 we describe the flat falling motion. In Section 7 we conclude this paper by studying the nearly falling flat motions of the disk.

This paper is a spin-off of a book project "The Geometry of Nonholonomically Constrained Systems", by R. H. Cushman, J. J. Duistermaat and J. Śniatycki.

## 2. Set up

We follow the geometric set up of [5]-Sec. 2, with some additions which will be needed in the proof of the asymptotic behaviour of the nearly flat falling disk. Although the equations of motion for the rolling disk are well-known since Vierkandt [16], Korteweg [10], [11], Appell [1], [2], we briefly review their derivation. Most of the text consists of the introduction of the many notations which we need in our analysis of the nearly flat falling disk.

### 2.1. The unconstrained disk

The position of a rigid body is obtained by applying an element of the Euclidean motion group  $E(3)$  in  $\mathbf{R}^3$  to a reference position of the body. A Euclidean motion is an affine linear map  $(A, a) : x \mapsto Ax + a : \mathbf{R}^3 \rightarrow \mathbf{R}^3$ , which consists of a rotation  $A \in SO(3)$  followed by a translation by a vector  $a \in \mathbf{R}^3$ .

Using the dot notation for derivatives with respect to time, we have that  $A^{-1} \dot{A}$  is an antisymmetric  $3 \times 3$ -matrix, and therefore there is a unique vector  $\omega(t) \in \mathbf{R}^3$  such that

$$\dot{A}x = A(\omega \times x), \quad x \in \mathbf{R}^3. \quad (2.1)$$

The vector  $\omega(t) \in \mathbf{R}^3$  is called the *angular velocity in body coordinates*. We take the center of mass of the body in its reference position to be the origin. Then the kinetic energy  $\mathcal{T}$  of the rigid body is equal to

$$\mathcal{T} = \langle I\omega, \omega \rangle / 2 + m \langle \dot{a}, \dot{a} \rangle / 2. \quad (2.2)$$

Here  $\langle \cdot, \cdot \rangle$  is the Euclidean inner product in  $\mathbf{R}^3$  and  $I$  is the *moments of inertia tensor* of the body, which is a positive definite symmetric  $3 \times 3$ -matrix. The directions of eigenvectors and the eigenvalues  $I_1, I_2, I_3$  of  $I$  are called the *axes of inertia* and *moments of inertia*, respectively. We choose the reference position of the body so that its axes of inertia are the axes of the standard basis vectors  $e_1, e_2, e_3$  of  $\mathbf{R}^3$ . Consequently,  $\langle I\omega, \omega \rangle = \sum_{j=1}^3 I_j \omega_j^2$ .

For the rolling disk, we have  $I_1 = I_2$  and

$$0 \leq I_3 \leq I_1 + I_2 = 2I_1, \quad (2.3)$$

where the equality

$$I_3 = I_1 + I_2 = 2I_1 \quad (2.4)$$

holds if and only if all the mass of the disk is in the plane of the rim. If the mass is uniformly distributed in the planar disk which has the rim as its boundary, then

$$I_1 = I_2 = m r^2 / 4, \quad I_3 = m r^2 / 2, \quad (2.5)$$

and the disk is called a *uniform disk*. If the mass is concentrated on the rim, then

$$I_1 = I_2 = m r^2/2, \quad I_3 = m r^2, \quad (2.6)$$

and the disk is called a *hoop*.

The potential energy of the disk in a constant vertical gravitational field is

$$\mathcal{V} = m g a_3, \quad (2.7)$$

where  $g$  is the gravitational acceleration and  $a_3$  is the height of the center of mass above the horizontal plane  $\mathbf{R}^2 \times \{0\}$  in  $\mathbf{R}^3$  on which the disk is rolling.

## 2.2. The phase space of the rolling disk

In the reference position the rim is in the horizontal plane  $\mathbf{R}^2 \times \{0\}$  in  $\mathbf{R}^3$ , with the center of the circular rim at the origin. Flat positions corresponds to  $A e_3 = \pm e_3$ . These positions are excluded from the phase space of positions and velocities of the disk, for when the disk is flat it has no well defined point of contact on which to roll.

Let

$$u = u(t) = A(t)^{-1} e_3, \quad (2.8)$$

and let  $\underline{u} = (u_1, u_2, 0)$  be the horizontal part of  $u$ . Let  $s$  be the point on the rim of the reference disk, which is mapped by  $(A, a) \in E(3)$  to the lowest point on the rim of the rolling disk. Then

$$s = s(u) = -r \|\underline{u}\|^{-1} \underline{u} = -r (1 - u_3^2)^{-1/2} \underline{u}, \quad (2.9)$$

where  $r$  is the radius of the rim. Note that  $u$  is a vector on the unit sphere in  $\mathbf{R}^3$  and that  $A e_3 \neq \pm e_3$  implies that  $e_3 \neq \pm u$ , and therefore  $\underline{u} \neq 0$ . The condition that the lowest point on the rim is in the horizontal plane  $\mathbf{R}^2 \times \{0\}$  means

$$a_3 = r (1 - u_3^2)^{1/2}. \quad (2.10)$$

This is a single holonomic constraint on the position  $(A, a) \in E(3)$  of the disk. Let  $Q$  denote the space of  $(A, a) \in E(3)$  which satisfy  $A e_3 \neq e_3$  and (2.10). Then  $Q$  is called the *position space* or *configuration space* of the rolling disk. It is a 5-dimensional analytic manifold.

The condition that the disk rolls *without slipping* means that, for each time  $t_0$ , the derivative of  $t \mapsto A(t) s(u(t_0)) + a(t)$  at  $t = t_0$  is equal to zero, that is,

$$\dot{a} = r (1 - u_3^2)^{-1/2} \dot{A} \underline{u} = r (1 - u_3^2)^{-1/2} A (\omega \times \underline{u}). \quad (2.11)$$

The vertical component of (2.11) is the time derivative of (2.10) and therefore follows from the holonomic constraint. The two horizontal components of (2.11) are *nonholonomic constraints* in the sense that these constraints on the velocities are not related to any constraints on the positions.

Let  $T_{(A,a)} Q$  denote the tangent space of  $Q$  at the point  $(A, a)$ . Then  $(\delta A, \delta a) \in T_{(A,a)} Q$  such that  $\delta a = r (1 - u_3^2)^{-1/2} (\delta A) \underline{u}$  are called *allowed virtual displacements*. For each  $(A, a) \in Q$ , the allowed virtual displacements form a codimension two linear subspace  $M_{(A,a)}$  of  $T_{(A,a)} Q$ . Therefore the disjoint union of the  $M_{(A,a)}$ , where  $(A, a)$  ranges over all points of  $Q$ , is a codimension two analytic vector subbundle  $M$  of the tangent bundle  $TQ$  of  $Q$ . It follows from the definition of  $Q$  and (2.11) that  $M$  consists of all positions and velocities which satisfy the holonomic and nonholonomic constraints, and therefore  $M$  is the *phase space* of the rolling disk. It is an 8-dimensional analytic manifold.

### 2.3. The equations of motion

As Lagrange [12]-Part. II, Sect. IV observed, if  $\mathcal{L} = \mathcal{L}(t, q, \dot{q})$  is a function of the time  $t$ , the position  $q$  and the velocity  $\dot{q}$ , then the expression  $[\mathcal{L}]_i = d/dt(\partial\mathcal{L}/\partial\dot{q}_i) - \partial\mathcal{L}/\partial q_i$ , computed in local coordinates, transforms as a covector. In other words,  $[\mathcal{L}]$  is an invariantly defined linear form of the tangent space  $T_q Q$  of the position manifold  $Q$  at the point  $q$ . This led Lagrange to the reformulation of Newton's law in the form that the force acting on the system is equal to  $[\mathcal{T}]$ , where  $\mathcal{T}$  is the kinetic energy of the system. If the force field is equal to  $-d\mathcal{V}$ , where  $\mathcal{V}$ , the potential energy, is a smooth function on  $Q$ , then the equations of motion take the form  $[\mathcal{T} - \mathcal{V}] = 0$ .

For nonholonomically constrained systems with the constraint  $\dot{q} \in M_q$ , where  $M_q$  is a linear subspace of  $T_q Q$ , the equations of motion take the form that at each instant the linear form  $[\mathcal{T} - \mathcal{V}]$  vanishes on  $M_q$ . These have been the generally accepted equations of motions for nonholonomic systems since Routh [14]-[No. 429], Chaplygin [4], and Korteweg [10]. It is a general principle that *the total energy*  $E = \mathcal{T} + \mathcal{V}$  is a constant of motion of such a nonholonomically constrained system.

Application of the vanishing of  $[\mathcal{T} - \mathcal{V}]$  on  $M_q$  to the rolling disk leads to

$$(I + m r^2)\dot{\omega} - m \langle \dot{\omega}, s \rangle s = (I \omega) \times \omega + m \langle s, \omega \rangle \dot{s} + m \langle \omega, s \rangle \omega \times s + m g u \times s, \quad (2.12)$$

which expresses  $\dot{\omega} = d\omega/dt$  in terms of  $\omega$ ,  $u = A^{-1} e_3$ ,  $s = s(u)$  as in (2.9), and  $\dot{s} = ds/dt$ . In turn  $\dot{s}$  can be expressed in terms of  $u$  and  $\dot{u}$ . From (2.8) and (2.1) we have the equation

$$\dot{u} = u \times \omega. \quad (2.13)$$

Thus (2.12) and (2.13) form a system of first order ordinary differential equations for  $(u, \omega)$ . The full equations of motion are obtained by including the equations (2.1) and (2.11) in the system.

Let  $E(2)$  be the group of all  $(B, b) \in E(3)$  such that  $B e_3 = e_3$  and  $b \in \mathbf{R}^2 \times \{0\}$ . Then  $E(2)$  is the group of Euclidean motions of the horizontal plane.  $E(2)$  is a symmetry group of the rolling disk, where  $(B, b)$  sends  $((A, a), (\dot{A}, \dot{a}))$  to  $((B A, B a + b), (B \dot{A}, B \dot{a}))$ . The vectors  $u$  and  $\omega$  are invariant under this action of  $E(2)$  and in fact parametrize the space of the  $E(2)$  orbits. In this way the  $E(2)$ -reduced space  $M/E(2)$ , the space of the  $E(2)$ -orbits, is identified with the  $(u, \omega)$ -space  $(S^2 \setminus \{\pm e_3\}) \times \mathbf{R}^3$ . Because the group  $E(2)$  leaves the vector field on  $M$  invariant, the flow of the vector field maps  $E(2)$ -orbits to  $E(2)$ -orbits. Therefore it induces a flow in  $M/E(2)$ , which is defined by the system (2.13), (2.12). For this reason the system (2.13), (2.12) is called the  *$E(2)$ -reduced system* for the rolling disk.

Because the rolling disk is a body of revolution, there is another "internal" symmetry group, namely the circle group  $S^1$  of rotations  $C$  of the reference disk about the vertical axis. Here  $C$  acts by sending  $((A, a), (\dot{A}, \dot{a}))$  to  $((A C^{-1}, a), (\dot{A} C^{-1}, \dot{a}))$ . It follows from (2.8) and (2.1) that under this action  $(u, \omega)$  is sent to  $(C u, C \omega)$ . Because the  $S^1$ - and  $E(2)$ -actions commute, there is an  $E(2) \times S^1$ -action on  $M$ , whose orbit space  $M/(E(2) \times S^1)$ , called the *fully reduced phase space*, can be identified with the space of  $S^1$ -orbits on  $(S^2 \setminus \{\pm e_3\}) \times \mathbf{R}^3$ . On  $(S^2 \setminus \{\pm e_3\}) \times \mathbf{R}^3$  we have the  $S^1$ -invariant polynomials

$$\sigma_1 := u_3, \quad \sigma_2 := u_1 \omega_2 - u_2 \omega_1, \quad \sigma_3 := u_1 \omega_1 + u_2 \omega_2, \quad \sigma_4 := \omega_3, \quad (2.14)$$

which actually form a global regular coordinate system on the fully reduced phase space. In these coordinates, the fully reduced phase space corresponds to the set of all  $(\sigma_1, \sigma_2, \sigma_3, \sigma_4)$  such that  $-1 < \sigma_1 < 1$ . That is,  $M/(E(2) \times S^1)$  is identified with  $] - 1, 1[ \times \mathbf{R}^3$ .

Again because the  $S^1$ -action leaves the  $E(2)$ -reduced vector field invariant, we have a dynamical

system on the fully reduced phase space  $] - 1, 1[ \times \mathbf{R}^3$ , which turns out to be defined by

$$\dot{\sigma}_1 = \sigma_2, \quad (2.15)$$

$$(I_1 + m r^2) \dot{\sigma}_2 = -(I_1 + m r^2) (1 - \sigma_1^2)^{-1} \sigma_1 \sigma_2^2 - I_1 (1 - \sigma_1^2)^{-1} \sigma_1 \sigma_3^2 + (I_3 + m r^2) \sigma_3 \sigma_4 + m g r \sigma_1 (1 - \sigma_1^2)^{1/2}, \quad (2.16)$$

$$I_1 \dot{\sigma}_3 = -I_3 \sigma_2 \sigma_4, \quad (2.17)$$

$$(I_3 + m r^2) \dot{\sigma}_4 = -m r^2 (1 - \sigma_1^2)^{-1} \sigma_2 \sigma_3. \quad (2.18)$$

Here (2.15) and (2.18) follow by taking the  $e_3$ -component of (2.13) and (2.12), respectively; whereas (2.17) follows by taking the inner product of (2.12) with  $s$ . To prove (2.16), one writes the total energy as

$$E = (I_1 + m r^2) (1 - \sigma_1^2)^{-1} \sigma_2^2 / 2 + I_1 (1 - \sigma_1^2)^{-1} \sigma_3^2 / 2 + (I_3 + m r^2) \sigma_4^2 / 2 + m g r (1 - \sigma_1^2)^{1/2}, \quad (2.19)$$

and then divides the equation  $dE/dt = 0$  by  $\sigma_2$ . This leads to (2.16) when  $\sigma_2 \neq 0$ . A continuity argument finally shows that (2.16) also holds for  $\sigma_2 = 0$ .

Our strategy will be to first study the  $E(2) \times S^1$ -reduced system in detail, where it will turn out that its generic solutions are periodic, a result already obtained by Vierkandt [16]-Eq. (21), p. 128. From the knowledge of the solutions of the reduced system we will then reconstruct the motion of the rolling disk using the formulas of the next subsection.

## 2.4. Reconstruction

The equations obtained in this subsection are new compared to [5]-Sec. 2. They are essential in the proof of the asymptotic formulas for the nearly falling disk.

The angular velocity  $\omega(t)$  in body coordinates, cf. (2.1), can be reconstructed from the unit vector  $u(t) = A(t)^{-1} e_3$  and the solutions  $\sigma_j(t)$ ,  $1 \leq j \leq 4$ , see (2.14), of the equations of motion for the fully reduced system, as follows:

$$\omega_1 = (-u_2 \sigma_2 + u_1 \sigma_3) / (1 - \sigma_1^2), \quad \omega_2 = (u_1 \sigma_2 + u_2 \sigma_3) / (1 - \sigma_1^2), \quad \omega_3 = \sigma_4. \quad (2.20)$$

Here we have used the identities  $u_1^2 + u_2^2 = 1 - u_3^2 = 1 - \sigma_1^2$ .

In order to reconstruct  $u(t) = A(t)^{-1} e_3$  from the  $\sigma_j(t)$ , we use the spherical coordinates

$$u = (\cos \varphi \cos \psi, \cos \varphi \sin \psi, \sin \varphi) \quad (2.21)$$

for the point  $u$  on the unit sphere. Note that  $\sin \varphi = u_3 = \sigma_1$ . The condition that  $A e_3 \neq e_3$ , or equivalently  $-1 < \sigma_1 < 1$ , gives  $-\pi/2 < \varphi < \pi/2$ , which implies that  $\cos \varphi > 0$ . Thus the angle  $\psi \in \mathbf{R}/2\pi\mathbf{Z}$  well defined and depends analytically on  $u$ .

With this notation we have  $u_1 \dot{u}_2 - u_2 \dot{u}_1 = (\cos^2 \varphi) \dot{\psi}$ . From (2.13) it follows that  $u_1 \dot{u}_2 - u_2 \dot{u}_1 = \sigma_3 \sigma_1 - (1 - \sigma_1^2) \sigma_4$ . Consequently,

$$\dot{\psi} = \sigma_3 \sigma_1 / (1 - \sigma_1^2) - \sigma_4. \quad (2.22)$$

Therefore  $\psi(t)$  is obtained from the motion of the fully reduced system by means of an integration.

Disregarding the internal rotations of the disk amounts to working in the  $S^1$ -reduced phase  $M/S^1$ . This space is parametrized by  $((v, a), (\nu, \dot{a}))$ , where

$$v = v(t) = A(t) e_3, \quad (2.23)$$

is the instantaneous normal in space to the plane of the rim, and

$$\dot{A} x = \nu \times (A x). \quad x \in \mathbf{R}^3. \quad (2.24)$$

Thus  $\nu$  is the *angular velocity of the disk in space coordinates*. The quantities  $v$  and  $\nu$  have a more direct interpretation in terms of the observed motion of the disk than the analogous quantities  $u$  and  $\omega$  in (2.8) and (2.1).

Note that the point  $x$  in body coordinates is at rest, if and only if  $0 = \dot{A}x + \dot{a} = A(\omega \times (x + r \|\underline{u}\|^{-1} \underline{u}))$  if and only if  $x \in -r \|\underline{u}\|^{-1} \underline{u} + \mathbf{R}\omega$  when  $\omega \neq 0$ . Here we have used the definition (2.1) of  $\omega$  and the non-slipping condition (2.11). It follows that in space coordinates the instantaneous motion of the disk is a rotation about the axis through the point of contact in the direction of angular velocity vector  $\nu$ , as to be expected from the non-slipping condition.

If we substitute  $x = e_3$  in (2.24) and then use (2.23) we obtain  $\dot{v} = \nu \times v$ . If  $A$  is given, then  $v = A^2 u$  and  $\nu = A\omega$ . This leads to the following expression of the  $\sigma_j$ , defined in (2.14), in terms of  $v$  and  $\nu$ .

$$\sigma_1 = \langle e_3, u \rangle = \langle e_3, A^{-1} e_3 \rangle = \langle A e_3, e_3 \rangle = v_3, \tag{2.25}$$

$$\sigma_2 = \dot{v}_3 = (\nu \times v)_3 = \nu_1 v_2 - \nu_2 v_1, \tag{2.26}$$

$$\sigma_3 + \sigma_1 \sigma_4 = \langle u, \omega \rangle = \langle A^{-2} v, A^{-1} \nu \rangle = \langle A^{-1} v, \nu \rangle = \langle e_3, \nu \rangle = \nu_3, \tag{2.27}$$

$$\sigma_4 = \langle \omega, e_3 \rangle = \langle A^{-1} \nu, e_3 \rangle = \langle \nu, A e_3 \rangle = \langle \nu, v \rangle. \tag{2.28}$$

The angular velocity  $\nu$  in space coordinates can be reconstructed from  $v$  and the  $\sigma_j$ , by solving the equations  $v_2 \nu_1 - v_1 \nu_2 = \sigma_2$ , see (2.26), and  $v_1 \nu_1 + v_2 \nu_2 = \sigma_4 - v_3 \nu_3 = \sigma_4 - \sigma_1 (\sigma_3 + \sigma_1 \sigma_4) = (1 - \sigma_1^2) \sigma_4 - \sigma_1 \sigma_3$ , see (2.28) and (2.27). This leads to

$$\nu_1 = A(\sigma) \nu_1 + B(\sigma) \nu_2, \quad \nu_2 = -B(\sigma) \nu_1 + A(\sigma) \nu_2, \tag{2.29}$$

where  $A(\sigma) := \sigma_4 - \sigma_1 \sigma_3 / (1 - \sigma_1^2)$  and  $B(\sigma) := \sigma_2 / (1 - \sigma_1^2)$ . We finally have equation (2.27) for  $\nu_3$ .

For the reconstruction of  $v$  we use the spherical coordinates

$$v = (\cos \varphi \cos \chi, \cos \varphi \sin \chi, \sin \varphi), \tag{2.30}$$

where  $\varphi$  is the same angle as in (2.21), because  $v_3 = \sigma_1 = u_3 = \sin \varphi$ , see (2.25). The condition  $\cos \varphi > 0$  implies that  $\chi \in \mathbf{R}/2\pi\mathbf{Z}$  is well defined and depends analytically on  $v$ . Similar to the proof of (2.22) we get  $(\cos^2 \varphi) \dot{\chi} = v_1 \dot{v}_2 - v_2 \dot{v}_1 = \sigma_3$ , where we have used (2.27) and (2.28). Therefore the angle  $\chi(t)$  is obtained by integrating

$$\dot{\chi} = \sigma_3 / (1 - \sigma_1^2). \tag{2.31}$$

By combining (2.21) for  $u = A^{-1} e_3$  and (2.30) for  $v = A e_3$ , we find that  $A$  is equal to the rotation about the  $e_3$ -axis through the angle  $-\psi - \pi$  followed by the rotation about the  $e_2$ -axis through the angle  $\varphi + \pi/2$  and followed by the rotation about the  $e_3$ -axis through the angle  $\chi$ . In other words,

$$(-\psi - \pi, \varphi + \pi/2, \chi) \in (\mathbf{R}/2\pi\mathbf{Z}) \times ] - \pi/2, \pi/2[ \times (\mathbf{R}/2\pi\mathbf{Z}) \tag{2.32}$$

are *Euler angles* for the rotation  $A$ . These angles form a regular system of coordinates on the set of all  $A \in \text{SO}(3)$  such that  $A e_3 \neq e_3$ . Note that the angles  $\psi(0)$  and  $\chi(0)$  are only defined modulo  $2\pi$ , but that the increases  $\psi(t) - \psi(0)$  and  $\chi(t) - \chi(0)$  of the angles  $\psi$  and  $\chi$  are well-defined real numbers, *not* taken modulo  $2\pi$ . In particular it makes sense to talk about the *number of times that the horizontal parts of  $u(t) = A(t)^{-1} e_3$  and  $v(t) = A(t) e_3$  have encircled the origin in  $\mathbf{R}^2$* .

Given the rotational motion  $A(t)$  and the angular velocity  $\omega(t)$  in body coordinates, the translational motion is obtained by integrating (2.11). In terms of the instantaneous normal  $v$  to the plane of the rim and the angular velocity  $\nu$  in space coordinates, (2.11) can be written as

$$\dot{a} = r (\sigma_4 \sin \chi - \dot{\varphi} \cos \varphi \cos \chi, -\sigma_4 \cos \chi - \dot{\varphi} \cos \varphi \sin \chi, -\dot{\varphi} \sin \varphi). \tag{2.33}$$

Finally observe that the point of contact  $p = p(t)$  of the rolling disk with the horizontal plane is equal to  $A s(u) + a$ . In view of (2.9) this is equal to

$$p = -r (1 - \sigma_1^2)^{-1/2} A \underline{u} + a. \tag{2.34}$$

Note that (2.21) implies that  $(1 - \sigma_1^2)^{-1/2} \underline{u} = (\cos \psi, \sin \psi, 0)$ . In terms of  $v$ ,  $\nu$ , and  $a$  the point of contact is given by

$$p = r(1 - \sigma_1^2)^{-1/2} \sigma_1 \underline{v} + \underline{a}, \quad (2.35)$$

which formula follows immediately from the definition  $v = A e_3$ .

### 3. A potential function on an interval

#### 3.1. Chaplygin's equations

In the third and fourth equation (2.17) and (2.18) of the fully reduced system we use (2.15) in order to replace  $d\sigma_1/dt$  by  $\sigma_2$ . Dividing both sides of the resulting equations by  $d\sigma_1/dt$ , we obtain

$$\frac{d\sigma_3}{d\sigma_1} = -\frac{I_3}{I_1} \sigma_4, \quad \frac{d\sigma_4}{d\sigma_1} = -\frac{m r^2}{I_3 + m r^2} \frac{\sigma_3}{1 - \sigma_1^2}. \quad (3.1)$$

Because Chaplygin [4]-Eq. (15) found a similar linear system of ordinary differential equations for an arbitrary solid of revolution which rolls on a horizontal plane, we will refer to (3.1) as *Chaplygin's equations*. Observe that for the rolling disk the system (3.1) has the symmetries

$$(\sigma_1, \sigma_3, \sigma_4) \mapsto (-\sigma_1, -\sigma_3, \sigma_4) \mapsto (-\sigma_1, \sigma_3, -\sigma_4) \mapsto (\sigma_1, -\sigma_3, -\sigma_4). \quad (3.2)$$

Chaplygin's equations form a homogeneous linear system of ordinary differential equations for  $\sigma_3$ ,  $\sigma_4$  as functions of  $\sigma_1$ , the coefficients of which are analytic functions of  $\sigma_1$  on  $] -1, 1[$ . It follows from the theory of such linear systems of ordinary differential equations, cf. [6]-Ch. 3, that for each  $(\bar{\sigma}_3, \bar{\sigma}_4) \in \mathbf{R}^2$  there is a unique  $\mathbf{R}^2$ -valued solution

$$\sigma_1 \mapsto (\sigma_3(\sigma_1; \bar{\sigma}_3, \bar{\sigma}_4), \sigma_4(\sigma_1; \bar{\sigma}_3, \bar{\sigma}_4)), \quad (3.3)$$

on the whole open interval  $] -1, 1[$ , such that  $\sigma_3(0; \bar{\sigma}_3, \bar{\sigma}_4) = \bar{\sigma}_3$  and  $\sigma_4(0; \bar{\sigma}_3, \bar{\sigma}_4) = \bar{\sigma}_4$ . Moreover the solution is an analytic function of  $\sigma_1 \in ] -1, 1[$  and depends linearly on the initial vector  $(\bar{\sigma}_3, \bar{\sigma}_4) \in \mathbf{R}^2$ .

Geometrically this means that the solution curves of the system (3.1) define an analytic fibration of the  $(\sigma_1, \sigma_3, \sigma_4)$ -space  $] -1, 1[ \times \mathbf{R}^2$ . The inverse of the analytic diffeomorphism

$$\psi : (\sigma_1, \bar{\sigma}_3, \bar{\sigma}_4) \mapsto (\sigma_1, \sigma_3(\sigma_1; \bar{\sigma}_3, \bar{\sigma}_4), \sigma_4(\sigma_1; \bar{\sigma}_3, \bar{\sigma}_4)) \quad (3.4)$$

of  $] -1, 1[ \times \mathbf{R}^2$  is a trivialization, whose fibers are parametrized by the first coordinate. More precisely, if  $\pi_2 : (\sigma_1, (\bar{\sigma}_3, \bar{\sigma}_4)) \mapsto (\bar{\sigma}_3, \bar{\sigma}_4)$  denotes the projection which forgets the first coordinate, then  $\pi_2 \circ \psi : ] -1, 1[ \times \mathbf{R}^2 \rightarrow \mathbf{R}^2$  is the flow of the linear system (3.1), and  $\pi := \pi_2 \circ \psi^{-1}$  is the projection of which the fibers are the solution curves of the system (3.1).

The fact, that the equations of motion of the fully reduced system imply the system (3.1), means that under the projection  $P : (\sigma_1, \sigma_2, \sigma_3, \sigma_4) \mapsto (\sigma_1, \sigma_3, \sigma_4)$  each solution of the fully reduced system is mapped into a fiber of  $\pi$ . Equivalently this means that the two components of the  $\mathbf{R}^2$ -valued function  $\pi \circ P$  are constants of motion. We shall write

$$\pi \circ P = (\bar{\sigma}_3, \bar{\sigma}_4) : ] -1, 1[ \times \mathbf{R}^3 \rightarrow \mathbf{R}^2, \quad (3.5)$$

where in the right hand side  $\bar{\sigma}_3$  and  $\bar{\sigma}_4$  are viewed as analytic functions on the fully reduced phase space  $] -1, 1[ \times \mathbf{R}^3$ . In this way, the quantities  $\bar{\sigma}_3, \bar{\sigma}_4$ , which are constants of motion, are at the same time seen as the initial values at  $\sigma_1 = 0$  of the solutions of the system (3.1), which parametrize these solutions, and as analytic functions on the phase space which are constants of motion for the rolling disk.

### 3.2. A conservative system in one degree of freedom

In the reduced phase space, the level sets of the integrals  $\bar{\sigma}_3, \bar{\sigma}_4$  are planar strips  $\Sigma$  parametrized by  $(\sigma_1, \sigma_2) \in ]-1, 1[ \times \mathbf{R}$ . On these strips we still have the total energy as a constant of motion  $E$ , see (2.19), and the solutions of the reduced system are confined to the level curves of  $E$  in the level strips of  $(\bar{\sigma}_3, \bar{\sigma}_4)$ . In this subsection we will describe the system on each level strip of  $(\bar{\sigma}_3, \bar{\sigma}_4)$  as a conservative one degree of freedom system on the interval  $] - 1, 1[$ , whose energy is the sum of a kinetic and a potential energy. This potential energy, which is different from the potential energy in (2.7), is called the *amended potential energy*. It depends on the parameters  $\bar{\sigma}_3, \bar{\sigma}_4$ . The use of the amended potential energy in the study of the rolling disk has been introduced before by Fedorov [8], O'Reilly [13], and Cushman, Hermans and Kempainen [5].

In terms of the coordinates  $(\sigma_1, \sigma_2)$ , the restriction to  $\Sigma$  of the total energy (2.19) is equal to

$$E = T(\sigma_1, \sigma_2) + V_{\bar{\sigma}_3, \bar{\sigma}_4}(\sigma_1), \tag{3.6}$$

where

$$T(\sigma_1, \sigma_2) := (I_1 + m r^2) (1 - \sigma_1^2)^{-1} \sigma_2^2 / 2 \tag{3.7}$$

plays the role of kinetic energy and

$$V_{\bar{\sigma}_3, \bar{\sigma}_4}(\sigma_1) := I_1 (1 - \sigma_1^2)^{-1} \sigma_3(\sigma_1; \bar{\sigma}_3, \bar{\sigma}_4)^2 / 2 + (I_3 + m r^2) \sigma_4(\sigma_1; \bar{\sigma}_3, \bar{\sigma}_4)^2 / 2 + m g r (1 - \sigma_1^2)^{1/2}. \tag{3.8}$$

is viewed as potential energy. Note that (3.8), the amended potential energy, is *not* the potential energy  $\mathcal{V}$  in (2.7),  $\mathcal{V}$  is only the last term in the right hand side of (3.8). The amended potential energy is invariant under the discrete symmetries (3.2) with the variables  $(\sigma_3, \sigma_4)$  being replaced by  $(\bar{\sigma}_3, \bar{\sigma}_4)$ .

In view of (2.15), we have a classical mechanical system in one degree of freedom, with the configuration space  $] - 1, 1[$  parametrized by  $\sigma_1$  and with the kinetic energy defined by the inertial mass  $M = I_1 + m r^2$  and the Riemannian structure  $(1 - \sigma_1^2)^{-1} (\dot{\sigma}_1)^2$ . The kinetic energy (3.7) simplifies if we parametrize the configuration space  $] - 1, 1[$  by arclength. This amounts to the substitution  $\sigma_1 = \sin \varphi$ , with  $-\pi/2 < \varphi < \pi/2$ , which is the same angle as in (2.21). Then  $(1 - \sigma_1^2)^{-1/2} \dot{\sigma}_1 = (\cos \varphi)^{-1} (\cos \varphi) \dot{\varphi} = \dot{\varphi}$ . So

$$E = M \dot{\varphi}^2 / 2 + V(\varphi), \tag{3.9}$$

where we use the notations

$$M := I_1 + m r^2 \quad \text{and} \quad V(\varphi) := V_{\bar{\sigma}_3, \bar{\sigma}_4}(\sin \varphi). \tag{3.10}$$

The conservation of energy  $\dot{E} = 0$  is equivalent to the *conservative Newtonian system*

$$M \ddot{\varphi} + V'(\varphi) = 0, \tag{3.11}$$

with inertial mass  $M$  and force equal to  $-V'(\varphi)$ , where  $V'(\varphi) = \partial V(\varphi) / \partial \varphi$ . Indeed,  $\dot{E}$  is equal to  $\dot{\varphi}$  times the left hand side of (3.11) and therefore (3.11) follows from  $\dot{E} = 0$  if  $\dot{\varphi} \neq 0$ . It then follows for  $\dot{\varphi} = 0$  by continuity. Note that the vector field in the  $(\varphi, \dot{\varphi})$ -plane is analytic because the fully reduced system in the strip  $\Sigma$  is analytic.

It follows from (2.25) that  $\varphi$  is equal to the angle between the oriented plane of the rim and the vertical axis, where the angle is taken to be positive if the upward vertical direction is on the positive side of the plane of the rim. If the solution  $t \mapsto \varphi(t)$  of (3.11) is known, then we know  $\sigma_1(t) = \sin \varphi(t)$ ,  $\sigma_2(t) = \dot{\sigma}_1(t)$ ,  $\sigma_3(t) = \sigma_3(\sigma_1(t); \bar{\sigma}_3, \bar{\sigma}_4)$  and  $\sigma_4(t) = \sigma_4(\sigma_1(t); \bar{\sigma}_3, \bar{\sigma}_4)$ , see (3.3), which is the solution of the fully reduced system. From this we can reconstruct the full motion of the disk as in Subsection 2.4.

### 3.3. The motion of the angle $\varphi$

For the purpose of references, we recall the classical description of the solutions of a conservative Newtonian system in one degree of freedom as in (3.11).

Choose a value  $E$  of the constant of motion (3.9) which is larger than the infimum of the potential function  $V$  on  $] -\pi/2, \pi/2[$ . That is, there exist  $\varphi \in ] -\pi/2, \pi/2[$  such that  $V(\varphi) < E$ . Let  $] \varphi_-, \varphi_+[$  be a connected component of the open set of all  $\varphi \in ] -\pi/2, \pi/2[$  such that  $V(\varphi) < E$ . Here  $\pi/2 \leq \varphi_- < \varphi_+ \leq \pi/2$ . Note that  $V(\varphi_-) = E = V(\varphi_+)$  if  $\varphi_-$  and  $\varphi_+$  both lie in  $] -\pi/2, \pi/2[$ . We have  $\dot{\varphi} = \pm ((2/M)(E - V(\varphi)))^{1/2}$ , with a constant sign as long as  $\varphi_- < \varphi(t) < \varphi_+$  for  $t$  on a given time interval. Separating variables and integrating yields the formula

$$t_1 - t_0 = \pm \int_{\varphi(t_0)}^{\varphi(t_1)} ((2/M)(E - V(\varphi)))^{-1/2} d\varphi \quad (3.12)$$

for the time needed to go from  $\varphi(t_0)$  to  $\varphi(t_1)$ . The solution  $t_1 \mapsto \varphi(t_1)$  of (3.11) is obtained by inverting the function  $\varphi(t_1) \mapsto t_1$  given by the right hand side of (3.12).

Take the plus sign in (3.12). If  $\varphi_+ < \pi/2$  and  $V'(\varphi_+) \neq 0$ , then  $V'(\varphi_+) > 0$  and the right hand side of (3.12) has a finite positive limit as  $\varphi(t_1) \uparrow \varphi_+$ . This means that  $\varphi(t)$  reaches  $\varphi_+$  at the first finite time  $t = t_+$ . It follows from (3.11) that  $\ddot{\varphi} < 0$  when  $t = t_+$ . Therefore the continuation of the solution for  $t > t_+$  is determined by taking the minus sign in (3.12), which implies that  $\varphi(t) = \varphi(2t_+ - t)$  for all  $t$ . If in addition  $\varphi_- > -\pi/2$  and  $V'(\varphi_-) \neq 0$ , the  $V'(\varphi_-) < 0$  and the solution will reach  $\varphi_-$  for the first finite time  $t = t_- > t_+$ . We have  $\varphi(t) = \varphi(2t_- - t)$  for all  $t$ . It follows that  $\varphi(t) = \varphi(2t_+ - t) = \varphi(2t_- - (2t_+ - t)) = \varphi(2(t_- - t_+) + t)$  for all  $t$ . We conclude that the solution is periodic with minimal positive period equal to  $2(t_- - t_+)$ , where  $\varphi(t)$  oscillates back and forth between  $\varphi_-$  and  $\varphi_+$ . The function  $t \mapsto \varphi(t)$  is monotonic during each leg, and is time-reversed during the next leg. The number  $t_- - t_+$  is equal to the right hand side of (3.12), with the plus sign and with the limits  $\varphi(t_0)$  and  $\varphi(t_1)$  replaced by  $\varphi_-$  and  $\varphi_+$ . Therefore the minimal positive period  $\tau$  is given by the convergent improper integral

$$\tau = 2 \int_{\varphi_-}^{\varphi_+} ((2/M)(E - V(\varphi)))^{-1/2} d\varphi. \quad (3.13)$$

The fact that for the generic solution the angle  $\varphi(t)$  oscillates periodically between  $\varphi_-$  and  $\varphi_+$  where  $-\pi/2 < \varphi_- < \varphi_+ < \pi/2$  had already been observed, for the uniform disk, by Vierkandt [16]-Eq. (21), p. 128.

If  $V'(\varphi_+) = 0$ , then  $(\varphi, \dot{\varphi}) = (\varphi_+, 0)$  is an equilibrium point in the phase plane  $P = ] -\pi/2, \pi/2[ \times \mathbf{R}^2$  of the first order system corresponding to (3.11), which in turn corresponds to an equilibrium point of the fully reduced system. Because  $E - V(\varphi) = V(\varphi_+) - V(\varphi) = O((\varphi - \varphi_+)^2)$  as  $\varphi \uparrow \varphi_+$ , the right hand side of (3.12) diverges as  $\varphi(t_1) \uparrow \varphi_+$ . Therefore the solution  $t \mapsto (\varphi(t), \dot{\varphi}(t))$  of the first order system in the phase plane converges to the equilibrium point  $(\varphi_+, 0)$  as  $t \rightarrow \infty$ . Choosing the minus sign in (3.12) a similar argument shows that the the solution  $t \mapsto (\varphi(t), \dot{\varphi}(t))$  converges to the equilibrium point  $(\varphi_+, 0)$  as  $t \rightarrow -\infty$ . Similar conclusions hold when  $\varphi_+$  is replaced by  $\varphi_-$ .

Now assume that  $\varphi_- = -\pi/2$ , and  $\limsup_{\varphi \downarrow -\pi/2} V(\varphi) < E$ , where  $E$  denotes the total energy of our solution. If  $\dot{\varphi}(t_0) < 0$ , then  $\varphi(t)$  is a monotonically decreasing function of  $t \geq t_0$ . Because the right hand side of (3.12), with the minus sign, has a finite limit as  $\varphi(t_1) \downarrow -\pi/2$ , and it follows that there is a finite time  $t_+ > t_0$  such that  $\varphi(t) \downarrow -\pi/2$  as  $t \uparrow t_+$ . The same conclusion holds if  $\dot{\varphi}(t_0) = 0$ , which implies that  $\varphi(t_0) = \varphi_+$ , and we assume that  $V'(\varphi_+) \neq 0$ , that is,  $\varphi_+$  is not an equilibrium point. Then  $V'(\varphi_+) > 0$  and therefore  $\ddot{\varphi}(t_0) < 0$ . If  $\varphi_+ < \pi/2$  and  $V'(\varphi_+) = 0$ , then  $\varphi(t) \equiv \varphi_+$  for all  $t \in \mathbf{R}$  if  $\varphi(t_0) = \varphi_+$ , and  $\varphi(t)$  converges monotonically increasing to  $\varphi_+$  as  $t \rightarrow \infty$  if  $\varphi(t_0) < \varphi_+$  and  $\dot{\varphi}(t_0) \geq 0$ , which implies that  $\dot{\varphi}(t_0) > 0$ , because  $V(\varphi(t_0)) < E$ .

A similar analysis can be given if  $\varphi_+ = \pi/2$  and  $\limsup_{\varphi \uparrow \pi/2} V(\varphi) < E$ . It follows that if  $\varphi_+ = \pm\pi/2$  and  $\limsup_{\varphi \rightarrow \pm\pi/2} V(\varphi) < E$ , then the vector field in the phase plane  $P$  is *incomplete* in the

sense that there are solutions which run out of every compact subset of  $P$  in a finite time. Because  $\varphi$  is the angle between the oriented plane of the rim and the vertical direction, the plane of the rim for such solutions approaches the horizontal position in a finite time. In other words, the disk *falls flat* in a finite time. The choice of the plus sign in (3.12) leads to a solution where the plane of the rim *rises* in a finite time from the horizontal position.

In Section 6 we will see that there are no other cases to be considered for the potential  $V_{\bar{\sigma}_3, \bar{\sigma}_4}$  in (3.8). This concludes our review of the properties of the conservative Newton system (3.11) in one degree of freedom.

### 3.4. A special case of falling flat

A simple special case of a solution occurs when  $\bar{\sigma}_3 = \bar{\sigma}_4 = 0$ . Because of the linear dependence of the solutions of the system (3.1) on the initial data, this is equivalent to the condition that  $\sigma_3(t) = \sigma_4(t) = 0$ . In view of (2.14) this implies that the angular velocity vector  $\omega$  defined by (2.1) is all the time horizontal and perpendicular to the vector  $u$  defined by (2.8).

From the definition (3.8) of the potential function  $V_{\bar{\sigma}_3, \bar{\sigma}_4}$  it follows that  $V_{0,0}(\sigma_1) = mgr(1 - \sigma_1^2)^{1/2}$  or, using the substitution  $\sigma_1 = \cos \varphi$ , that  $V(\varphi) = mgr \cos \varphi$  for  $-\pi/2 < \varphi < \pi/2$ . Therefore the conservative Newtonian system (3.11) is equal to the *mathematical pendulum* on the upper semicircle of radius  $r$ , the “inverted pendulum keeling over” of O’Reilly [13]-Sec. 5. Because all of its solutions (except for the unstable equilibrium  $(\varphi, \dot{\varphi}) = (0, 0)$  and the solutions with the same total energy which converge to  $(0, 0)$ ) reach  $\varphi = \pm\pi/2$  in a finite time, we conclude that the disk falls flat in a finite time when  $\bar{\sigma}_3 = \bar{\sigma}_4 = 0$ . Thus the vector field in the phase space of the rolling disk is *incomplete* in the sense that not all solutions are defined for all time.

We now reconstruct the motion of the disk when  $\bar{\sigma}_3 = \bar{\sigma}_4 = 0$ . In combination with  $\sigma_3 = \sigma_4 = 0$ , the equation (2.22) implies that  $\dot{\psi} = 0$ . Therefore the angle  $\psi$  is constant. Applying a rotation in body coordinates, which is an element of the  $S^1$  symmetry group, we can arrange that  $\psi = \pi$ . In other words,

$$A(t)^{-1} e_3 = u(t) = -\cos \varphi(t) e_1 + \sin \varphi(t) e_3. \quad (3.14)$$

From (2.11) and (3.14) we obtain  $\dot{a} = -r \dot{A} e_1$ , which integrated gives

$$a(t) = a(0) - r(A(t) - A(0)) e_1.$$

In view of (2.34) the above equation implies that the point of contact is  $p = -r A(0) e_1 + a(0)$ . Therefore the point of contact  $p$  is constant. Using an element of the translation subgroup of the symmetry group  $E(2)$ , we can arrange that  $p = 0$ . Having done this, the position of the center of mass of the disk in space is given by  $a(t) = r A(t) e_1$ . It follows from (2.31) and  $\sigma_3 = 0$  that the angle  $\chi(t)$  in (2.30) is constant. Using a suitable rotation  $B$  about the vertical axis in the space coordinates, which leaves the vector  $u$  fixed and maps  $v$  to  $Bv$ , we can arrange that  $\chi = 0$ . This means that

$$A(t) e_3 = v(t) = \cos \varphi(t) e_1 + \sin \varphi(t) e_3. \quad (3.15)$$

Equations (3.14) and (3.15) imply that  $A(t)$  is a rotation about the  $e_2$ -axis through the angle  $\varphi(t) + \pi/2$ , see for instance (2.32). Thus the disk is rotating about the  $e_2$ -axis, which passes through the point of contact  $p = 0$ , where all the time the  $e_2$ -axis is contained in the plane of the rim.

The above motion of the disk falling flat has the full motion of the mathematical pendulum as its analytic continuation. In the analytic continuation, the disk is attached to the horizontal plane at its fixed point of contact and is allowed to pass through the horizontal plane.

In Section 7 we will investigate the motions when the disk comes close to a flat position but then rises up. In the fully reduced phase space these motions converge to a motion for  $\varphi(t)$  where at the horizontal position  $\varphi = \pm\pi/2$  we have an elastic reflection. At this moment the nonzero  $\dot{\varphi}(t)$  changes its sign, after which the motion continues in the opposite direction, see Lemma 5. The description of the limiting motion in the unreduced phase space is subtler, see Subsections 7.2 and 7.3.

## 4. Scaling

In this section we rescale Chaplygin's equations (3.1) to eliminate superfluous parameters. This will simplify the formulas in the proofs of our asymptotic results considerably.

Consider the scaling defined by

$$\sigma_3 = -(I_3/I_1)bx, \quad \sigma_4 = by, \quad \sigma_1 = z, \quad (4.1)$$

where  $x, y, z$  are new variables and  $b > 0$  is a positive constant. Then Chaplygin's equations (3.1) lead to the *rescaled Chaplygin equations*

$$x'(z) = y(z), \quad y'(z) = c(1 - z^2)^{-1}x(z), \quad (4.2)$$

where

$$c = mr^2 I_3 / ((I_3 + mr^2) I_1). \quad (4.3)$$

Note that the rescaled Chaplygin equations imply that  $x(z)$  satisfies the second order linear ordinary differential equation

$$x''(z) = c(1 - z^2)^{-1}x(z) \quad (4.4)$$

for  $x(z)$ .

The function

$$\tilde{V} = I_1(1 - \sigma_1^2)^{-1}\sigma_3^2/2 + (I_3 + mr^2)\sigma_4^2/2 + mgr(1 - \sigma_1^2)^{1/2}$$

of  $(\sigma_1, \sigma_3, \sigma_4) \in ]-1, 1[ \times \mathbf{R}^2$  is equal to  $V \circ \psi^{-1}$ , where  $V : (\sigma_1, \bar{\sigma}_3, \bar{\sigma}_4) \mapsto V_{\bar{\sigma}_3, \bar{\sigma}_4}(\sigma_1)$ , see (3.8) and (3.4). If we substitute (4.1) in  $\tilde{V}$  with

$$b := (mgr)^{1/2}(I_3 + mr^2)^{-1/2}, \quad (4.5)$$

then  $\tilde{V} = mgr\tilde{W}$ , where

$$\tilde{W}(z, x, y) := d(1 - z^2)^{-1}x^2/2 + y^2/2 + (1 - z^2)^{1/2}, \quad (4.6)$$

and

$$d = I_3^2 / (I_1(I_3 + mr^2)). \quad (4.7)$$

If  $z \mapsto (x(z; X, Y), y(z; X, Y))$  denotes the solution of the rescaled Chaplygin equations (4.2) such that  $x(0; X, Y) = X$  and  $y(0; X, Y) = Y$ , then we write

$$W_{X, Y}(z) := \tilde{W}(z, x(z, X, Y), y(z, X, Y)). \quad (4.8)$$

It follows that  $V_{\bar{\sigma}_3, \bar{\sigma}_4} = mgrW_{X, Y}(z)$  if we take

$$\bar{\sigma}_3 = -\frac{I_3}{I_1}bX \quad \text{and} \quad \bar{\sigma}_4 = bY. \quad (4.9)$$

If  $f$  is any function of  $(z, x, y)$ , then we have

$$\frac{d}{dz}f(z, x(z; X, Y), y(z; X, Y)) = (\mathcal{C}f)(z, x(z; X, Y), y(z; X, Y)),$$

where  $\mathcal{C} := \partial/\partial z + y\partial/\partial x + c(1 - z^2)^{-1}\partial/\partial y$  denotes the vector field in the  $(z, x, y)$ -space  $] -1, 1[ \times \mathbf{R}^2$  defined by the rescaled Chaplygin equations (4.2), viewed as a partial differential operator. This leads to

$$\mathcal{C}\tilde{W} := \frac{dW_{X, Y}(z)}{dz} = d(1 - z^2)^{-2}zx^2 + (d + c)(1 - z^2)^{-1}xy - (1 - z^2)^{-1/2}z, \quad (4.10)$$

where in the right hand side we substitute  $x = x(z; X, Y)$  and  $y = y(z; X, Y)$ .

As a result of our rescaling, we have only two dimensionless parameters in our equations, the parameter  $c$  in the rescaled Chaplygin equations (4.2), and the parameter  $d$  in the rescaled potential energy function  $W_{X,Y}$ , see (4.8) and (4.6). These parameters are subject to the inequalities  $c > 0$ ,  $d > 0$ , and  $c + d \leq 2$ , where in view of (2.3) the third one follows from  $c + d = I_3/I_1 \leq 2$ . Note that (2.4) implies that  $c + d = 2$  if and only if all the mass is in the plane of the rim. For the *uniform disk*, the disk with uniform mass distribution, (2.5), (4.3), (4.7) imply that  $c = 4/3$  and  $d = 2/3$ . For the *hoop*, when the mass is concentrated on the rim, it follows from (2.6), (4.3), (4.7) that  $c = 1$  and  $d = 1$ .

## 5. The solutions of Chaplygin's equations

The rescaled Chaplygin equations (4.2) have singular points at  $z = \pm 1$ , which correspond to the flat position of the disk. In this section we investigate the asymptotic behaviour of the solutions of (4.2) as  $z \rightarrow \pm 1$ , which we need in our investigation of the motion of the flat and nearly flat falling disk.

It has been observed by Chaplygin [4], in the paragraph preceding formula (22), that the solutions of (4.2) can be expressed in terms of Legendre functions, and therefore in terms of hypergeometric functions. This observation has also been made independently by Korteweg [10]-Eqs. (52), (53), [11], Apell [1], and Gallop, see Routh [15]-No. 244. In most papers on the rolling disk, the needed properties of the solutions of (4.2) are obtained by citing the appropriate properties of the hypergeometric functions from the literature on special functions. In order to make our presentation more self-contained, we will derive the required asymptotic properties of the solutions of (4.2), as  $z \rightarrow \pm 1$ , directly from the differential equations (4.2).

### 5.1. A recessive solution

We begin by finding a recessive solution at  $z = -1$  of the rescaled Chaplygin equations and then we use the Wronskian to find the general solution.

If we rewrite equation (4.4) as  $2(1+z)x''(z) = cx(z) + (1+z)^2 x''(z)$ , we see that it is satisfied by the formal power series

$$r(z) = \sum_{n=1}^{\infty} r_n (1+z)^n \quad (5.1)$$

if and only if the coefficients  $r_n$  satisfy the recurrence relation

$$r_{n+1} = \frac{c + n(n-1)}{2(n+1)n} r_n, \quad n \geq 1. \quad (5.2)$$

The relations (5.2) determine the coefficients uniquely up to the common factor  $r_1$ , we will choose

$$r_1 = 1. \quad (5.3)$$

The ratio test shows that the radius of convergence of (5.1) is 2. It follows that (4.4) has a unique solution which is analytic at  $z = -1$  and satisfies  $r(-1) = 0$  and  $r'(-1) = 1$ . This solution does not have an analytic extension to any neighborhood of  $z = 1$ , because otherwise the fact that  $z = \pm 1$  are the only singular points of (4.4) would imply that  $r(z)$  has an analytic extension to the whole complex plane, in contradiction with the fact that the radius of convergence is equal to 2. In particular the power series (5.1) represents a solution of (4.4) for all  $z \in [-1, 1[$ , where the convergence becomes slow when  $z$  is close to  $+1$ .

Because  $c > 0$ , (5.3) and (5.2) imply that  $r_n > 0$  for every  $n \geq 1$ . In particular it follows that  $r(z) > 0$  and  $r'(z) > 0$  for every  $z \in ]-1, 1[$ .

For later use we prove

**Lemma 1.** *There is a function  $u(z)$  which is analytic in  $z$  at  $z = -1$ , such that*

$$r(z)^{-2} = (1+z)^{-2} - \frac{c}{2}(1+z)^{-1} + u(z). \quad (5.4)$$

*Proof.* It follows from (5.2) and (5.3) that  $r(z) = (1+z)s(z)$ , where  $s(z)$  is analytic at  $z = -1$ ,  $s(-1) = 1$  and  $s'(-1) = c/4$ . Therefore  $r(z)^{-2} = (1+z)^{-2}s(z)^{-2}$ , where  $t(z) = s(z)^{-2}$  is analytic at  $z = -1$ ,  $t(-1) = 1$ , and  $t'(-1) = -2s'(-1) = -c/2$ . ■

## 5.2. The general solution

In this subsection we study the asymptotic behaviour of the general solutions of the rescaled Chaplygin equations as  $z \downarrow -1$ . To do this we first prove

**Lemma 2.** *There exists a function  $v(z)$  which is analytic at  $z = -1$  and satisfies  $v(-1) = 1$ , such that the solution  $x(z)$  of (4.4) with  $x(0) = X$  and  $x'(0) = Y$  is given by*

$$x(z) = \frac{X}{r(0)} r(z) + (X r'(0) - Y r(0)) \left( \frac{c}{2} r(z) \ln(1+z) + v(z) \right). \quad (5.5)$$

*Proof.* Because  $(x'r - xr')' = x''r - xr'' = c(1-z^2)^{-1}(xr - xr') = 0$ , the Wronski determinant  $w := x'(z)r(z) - x(z)r'(z)$  is a constant, equal to

$$w = x'(0)r(0) - x(0)r'(0) = Yr(0) - Xr'(0). \quad (5.6)$$

Integrating the identity  $(x/r)' = (x'r - xr')/r^2 = w/r^2$  from 0 to  $z$  and multiplying the resulting equation by  $r(z)$ , we obtain

$$x(z) = \frac{X}{r(0)} r(z) + w r(z) \int_0^z \frac{1}{r(\zeta)^2} d\zeta, \quad -1 < z < 1. \quad (5.7)$$

Inserting (5.4) in (5.7) and carrying out the integration, we arrive at

$$x(z) = \frac{X}{r(0)} r(z) + w r(z) \left( -\frac{1}{1+z} - \frac{c}{2} \ln(1+z) + \tilde{u}(z) \right),$$

where  $\tilde{u}(z) := \int_0^z u(\zeta) d\zeta$  is analytic in  $z$  at  $z = -1$ . Using the fact that  $r(-1) = 0$  and  $r'(-1) = 1$ , we obtain (5.5), where  $v(z) := r(z)((1+z)^{-1} - \tilde{u}(z))$  is analytic in  $z$  at  $z = -1$  and  $v(-1) = r'(-1) = 1$ . ■

We now draw some conclusions from (5.5). It follows that  $x(z)$  has a finite limit  $w_- := Xr'(0) - Yr(0) = -w$  as  $z \downarrow -1$ . This limit is equal to zero if and only if the Wronski determinant is equal to zero, which means that  $x(z)$  is a constant multiple of  $r(z)$ . For this reason  $r(z)$  is called the *normalized recessive solution* of (4.4) at  $z = -1$ . Every solution of (4.4) which has a nonzero limit for  $z \downarrow -1$  is called a *dominant solution* of (4.4) at  $z = -1$ .

Differentiating (5.5) gives

$$x'(z) = \frac{X}{r(0)} r'(z) + w_- \left( \frac{c}{2} \left( \frac{r(z)}{1+z} + \ln(1+z) r'(z) \right) + v'(z) \right).$$

This shows that

$$x'(z) = y(z) \sim w_- \frac{c}{2} \ln(1+z) \quad \text{as } z \downarrow -1. \quad (5.8)$$

Therefore  $y(z) = x'(z)$  has an infinite limit as  $z \downarrow -1$  if  $w_- \neq 0$ . The sign of this limit is opposite to the sign of  $w_-$ . If  $w_- = 0$  then  $y(z) = x'(z) = (X/r(0)) r'(z)$  converges to  $X/r(0)$  as  $z \downarrow -1$ .

Because equation (4.4) has the discrete symmetry  $z \leftrightarrow -z$ , the function  $\xi : z \mapsto x(-z)$  is another solution with  $\xi(0) = X$  and  $\xi'(0) = -Y$ . Therefore (5.5) remains valid if we replace  $x(z)$  and  $Y$  by  $x(-z)$  and  $-Y$ , respectively, and then replace  $z$  by  $-z$ . This gives

$$x(z) = \frac{X}{r(0)} r(-z) + (X r'(0) + Y r(0)) \left( \frac{c}{2} \ln(1-z) r(-z) + v(-z) \right). \quad (5.9)$$

Recall that the function  $v(z)$  is analytic at  $z = -1$  and  $v(-1) = 1$ . This implies that  $x(z)$  converges to  $w_+ := X r'(0) + Y r(0)$  as  $z \uparrow 1$ . Similarly, we obtain

$$x'(z) = -\frac{X}{r(0)} r'(-z) - w_+ \left( \frac{c}{2} \left( \frac{r(-z)}{1-z} + \ln(1-z) r'(-z) \right) + v'(-z) \right),$$

which gives

$$y(z) = x'(z) \sim -w_+ \frac{c}{2} \ln(1-z) \quad \text{as } z \uparrow 1, \quad (5.10)$$

because  $r(-1) = 0$  and  $r'(-1) = 1$ . Therefore  $x'(z) = y(z)$  has an infinite limit for  $z \uparrow 1$  if  $w_+ \neq 0$ . Moreover the limit has the same sign as  $w_+$ . If  $w_+ = 0$ , then  $y(z) = x'(z) = -(X/r(0)) r'(-z)$ , which converges to  $-X/r(0)$  as  $z \uparrow 1$ .

The relation between the solutions of (4.2) and hypergeometric functions, which in turn can be expressed in gamma functions can be used to prove the formulas

$$r(0) = \Gamma(3/2)/(\Gamma(5/4 - \sqrt{1-4c}/4) \Gamma(5/4 + \sqrt{1-4c}/4)), \quad (5.11)$$

$$r'(0) = \Gamma(1/2)/(\Gamma(3/4 - \sqrt{1-4c}/4) \Gamma(3/4 + \sqrt{1-4c}/4)), \quad (5.12)$$

for  $r(0)$  and  $r'(0)$  in terms of gamma functions. Note that the physically relevant domain for  $c$  is  $0 < c \leq 2$ , which has a non-empty intersection with the domain  $c > 1/4$ , where the arguments in the gamma functions in the denominator of (5.11) and (5.12) are non-real complex conjugate complex numbers. For the numerical computation of  $r(0)$  and  $r'(0)$ , the power series (5.1), where the coefficients are determined by  $r_1 = 1$  and the recurrence relation (5.2), is at least as adequate as the numerical computation of the right hand sides of (5.11) and (5.12). Both representations of  $r(0)$  and  $r'(0)$  yield that these numbers depend in an entire analytic fashion on  $c \in \mathbf{C}$ .

We finally observe that we have parametrized our solutions  $x(z)$  of (4.4) by  $X = x(0)$  and  $Y = x'(0)$ , which leads to a basis of solutions where the first solution is the one for which  $x(0) = 1$ ,  $x'(0) = 0$ , and the second solution is the one for which  $x(0) = 0$ ,  $x'(0) = 1$ . According to (4.9),  $X = 0$  if and only if  $\bar{\sigma}_3 = 0$ , and  $Y = 0$  if and only if  $\bar{\sigma}_4 = 0$ . According to (2.14), we have  $\sigma_3 = 0$  when the disk is rolling vertically along a straight line, because then  $\omega_1 = \omega_2 = 0$ , whereas  $\sigma_4 = 0$  when the disk is spinning vertically about a vertical axis in the plane of the rim. Therefore these special steady motions lie over the coordinate axes in the  $(\sigma_3, \sigma_4)$ -plane.

On the other hand, in the study of the falling disk the asymptotic properties of the solutions of (4.4) are essential, and then one can argue that it is more natural to take as a basis a recessive solution at  $z = -1$  together with a recessive solution at  $z = 1$ . This is the choice of the basis made in most papers on the rolling disk, including ones which do not deal specifically with falling disks. With respect to such a basis, the special steady motions mentioned in the previous paragraph are lying over the union of two straight lines through the origin which are different from the coordinate axes.

## 6. Falling flat

In this section we give precise conditions when the disk falls flat. Furthermore we study the limit behaviour of the disk when it falls flat.

### 6.1. When it does not fall flat

In this subsection we give conditions when the disk does *not* fall flat. In Subsection 6.2 we shall prove conversely that if these conditions are not satisfied, then the disk actually does fall flat.

Because the “kinetic energy”  $T$  in (3.7) is nonnegative and the total energy  $E$  is a constant of the motion, it follows that during the motion in the fully reduced phase space we have  $V_{\bar{\sigma}_3, \bar{\sigma}_4}(\sigma_1) \leq E$ . Therefore, if the upper limit of  $V_{\bar{\sigma}_3, \bar{\sigma}_4}(\sigma_1)$  as  $\sigma_1 \rightarrow \pm 1$  is  $> E$ , then  $\sigma_1$  remains bounded away from  $\pm 1$ . In other words, the angle between the plane of the rim of the rolling disk and the horizontal plane remains bounded away from zero. Thus the disk does not fall flat.

We now prove a much stronger statement about the asymptotic behaviour of  $V_p(\sigma_1)$  as  $\sigma_1 \rightarrow \pm 1$ , provided that the point  $p = (\bar{\sigma}_3, \bar{\sigma}_4)$  does not lie on one of the one dimensional linear subspaces  $l_{\pm}$  defined by

$$I_1 r'(0) \bar{\sigma}_3 \mp I_3 r(0) \bar{\sigma}_4 = 0. \quad (6.1)$$

Here the positive constants  $r(0)$  and  $r'(0)$  can be read off from (5.1), (5.2), (5.3), or alternatively from (5.11), (5.12), with  $c$  as in (4.3). In what follows the quantity

$$\eta_{\pm} := I_1 r'(0) \bar{\sigma}_3 \mp I_3 r(0) \bar{\sigma}_4 \quad (6.2)$$

will be used as a coordinate relative to  $l_{\pm}$ . If  $\eta_{\pm} \neq 0$ , then  $p$  lies on one side of  $l_{\pm}$  depending on the sign of  $\eta_{\pm}$ . If  $\eta_{\pm} = 0$  then  $p \in l_{\pm}$ . The distance from  $p$  to  $l_{\pm}$  is of the same order as  $|\eta_{\pm}|$ .

**Lemma 3.** *If  $p = (\bar{\sigma}_3, \bar{\sigma}_4) \notin l_{\pm}$ , then*

$$V_p(\sigma_1) \sim \eta_{\pm}^2 / 4I_1 (1 \mp \sigma_1) \quad \text{as } \sigma_1 \rightarrow \pm 1 \quad (6.3)$$

and

$$V'_p(\sigma_1) \sim \pm \eta_{\pm}^2 / 4I_1 (1 \mp \sigma_1)^2 \quad \text{as } \sigma_1 \rightarrow \pm 1. \quad (6.4)$$

The asymptotic relations are locally uniform for  $p \in \mathbf{R}^2 \setminus l_{\pm}$ .

*Proof.* Write  $a := X/r(0) = -I_1 \bar{\sigma}_3 / (I_3 b r(0))$  and

$$\epsilon := X r'(0) \pm Y r(0) = -\eta_{\pm} / (I_3 b), \quad (6.5)$$

see (4.9). It follows that  $p \notin l_{\pm}$  if and only if  $\epsilon \neq 0$ . It follows from Lemma 2 and (5.9) that

$$x(z) = a r(\mp z) + \epsilon [(c/2) r(\mp z) \ln(1 \mp z) + v(\mp z)],$$

where  $r(z) \sim 1 + z$  and  $v(z) \sim 1$  as  $z \rightarrow -1$ . Therefore  $x(z) \sim \epsilon$  as  $z \rightarrow \pm 1$ . Similarly

$$y(z) = x'(z) = \mp \{a r'(\mp z) + \epsilon [(c/2)(r'(\mp z) \ln(1 \mp z) + r(\mp z)/(1 \mp z)) + v'(\mp z)]\},$$

where  $r'(z) \sim 1$ ,  $r(z)/(1+z) \sim 1$  and  $v'(z) = O(1)$  as  $z \rightarrow -1$ . Therefore  $y(z) \sim \mp \epsilon (c/2) \ln(1 \mp z)$  as  $z \rightarrow \pm 1$ . Because

$$1 - z^2 = (1 - z)(1 + z) \sim 2(1 \mp z) \quad \text{as } z \rightarrow \pm 1, \quad (6.6)$$

it follows that the rescaled potential function  $W_{X,Y}$  in (4.8), (4.6) satisfies

$$\begin{aligned} W_{X,Y}(z) &\sim (1/2)d\epsilon^2/2(1 \mp z) + (1/2)\epsilon^2 (c^2/4) \ln^2(1 \mp z) + O(1) \\ &\sim d\epsilon^2/4(1 \mp z) \quad \text{as } z \rightarrow \pm 1. \end{aligned} \quad (6.7)$$

This implies (6.3), in view of the substitutions (4.8) and (4.9).

The function  $\widetilde{CW} = W'_{X,Y}(z)$  in (4.10) satisfies

$$\begin{aligned} \widetilde{CW} &= d(1 - z^2)^{-2} z x^2 + (d + c)(1 - z^2)^{-1} x y - (1 - z^2)^{-1/2} z \\ &\sim \pm (d/4)(1 \mp z)^{-2} \epsilon^2 + O((1 \mp z)^{-1} \ln^2(1 \mp z)) + O((1 \mp z)^{1/2}) \\ &\sim \pm (d/4)(1 \mp z)^{-2} \epsilon^2 \quad \text{as } z \rightarrow \pm 1. \end{aligned} \quad (6.8)$$

This implies (6.3). ■

The right hand side of (6.4) is equal to the derivative of the right hand side of (6.3). In general it is not true that the derivative of an asymptotic approximation of a function is an asymptotic approximation of the derivative of the function. For the inverse operation of integration such a statement is true, and therefore (6.3) can be considered as a consequence of (6.4).

Let  $(\bar{\sigma}_3, \bar{\sigma}_4) \in \mathbf{R}^2 \setminus (l_- \cup l_+)$ . It follows from (6.3) that the level set of the total energy (3.6) on the  $(\sigma_1, \sigma_2)$ - plane, which is a constant of motion, is a compact subset of  $] - 1, 1[ \times \mathbf{R}$ . This implies that the vector field in the  $(\sigma_1, \sigma_2)$ -plane is complete, in the sense that all its solutions are defined for all  $t \in \mathbf{R}$ . This also follows from the description of the solutions of the conservative Newton system (3.11) in Subsection 3.3. The solutions are either equilibrium points, corresponding to the relative equilibria of the rolling disk, or asymptotic to unstable equilibrium points, or nonconstant periodic functions of  $t$ , with  $\sigma_1$  oscillating periodically between a minimal and maximal value in the interval  $] - 1, 1[$ . Note that (6.4) implies that, for given values  $(\bar{\sigma}_3, \bar{\sigma}_4) \notin l_{\pm}$  of the integrals, there are no relative equilibria with the plane of the rim of the disk almost horizontal.

### 6.2. When it falls flat

We now discuss when the disk falls flat. The next lemma shows that we have a strong dichotomy.

**Lemma 4.** *Let  $p = (\bar{\sigma}_3, \bar{\sigma}_4) \in l_{\pm}$ . Then the function  $\varphi \mapsto V_p(\sin \varphi)$  has an extension to an analytic function  $V(\varphi)$  on a neighborhood of  $\varphi = \pm \pi/2$ . This extension satisfies*

$$V(\pm \pi/2) = p \bar{\sigma}_3^2, \quad p = I_1^2 (I_3 + m r^2)/(2I_3^2 r(0)^2), \tag{6.9}$$

and

$$V'(\pm \pi/2) = \mp m g r. \tag{6.10}$$

In particular,  $V(\varphi)$  has a strict local minimum at  $\varphi = \pm \pi/2$ .

*Proof.* We use the notation of the proof of Lemma 3. The hypothesis  $p \in l_{\pm}$  implies that  $X r'(0) \mp Y r(0) = 0$ . From (5.5) and (5.9) it follows that  $x(z) = X r(\mp z)/r(0)$  and  $y(z) = x'(z) = \mp X r'(\mp z)/r(0)$ . Here  $r(z)$  is analytic and  $r(z) = (1 + z) + O((1 + z)^2)$  for  $z$  in a neighborhood of  $-1$ . If we substitute  $z = \sin \varphi$ , then the mapping  $\varphi \mapsto \cos \varphi$  is a regular change of coordinates for  $\varphi$  near  $\pi/2$ , and

$$1 \mp z = 1 \mp \sin \varphi = 1 - (1 - \cos^2 \varphi)^{1/2} \sim (1/2) \cos^2 \varphi. \tag{6.11}$$

This implies that  $r(\mp z) \sim (1/2) \cos^2 \varphi$ . Therefore  $\varphi \mapsto r(\mp z)^2 / \cos^2 \varphi$  extends to an analytic function with a double zero at  $\mp \pi/2$ . In view of (6.11) we find that  $r'(\mp z)^2 = 1 + O(\cos^2 \varphi)$ . Substituting these asymptotic formulas in (4.8), (4.6) we obtain that

$$W_{X,Y}(\sin \varphi) = X^2/2r(0)^2 + \cos \varphi + O(\cos^2 \varphi),$$

and therefore  $\varphi \mapsto W_{X,Y}(\sin \varphi)$  has an analytic extension to a neighborhood of  $\varphi = \mp \pi/2$ . Moreover  $W_{X,Y}(\mp 1) = X^2/2r(0)^2$  and the derivative at  $\varphi = \mp \pi/2$  of  $\varphi \mapsto W_{X,Y}(\sin \varphi)$  is equal to  $\mp 1$ . Using the substitutions  $\tilde{V} = m g r \tilde{W}$ , (4.9) and (4.5), the lemma follows. ■

Assume that  $(\bar{\sigma}_3, \bar{\sigma}_4) \in l_- \setminus \{0\} = l_- \setminus (l_+ \cap l_-)$  and that  $E > V(-\pi/2)$ . Let  $V < E$  denote the set of all  $\varphi \in ] - \pi/2, \pi/2[$  such that  $V(\varphi) < E$ . From  $V'(-\pi/2) > 0$ , see (6.10), it follows that  $V < E$  has a connected component of the form  $] - \pi/2, \varphi_+[$ , for some  $\varphi_+ \in ] - \pi/2, \pi/2[$ . Note that  $(\bar{\sigma}_3, \bar{\sigma}_4) \notin l_+$  implies that  $\varphi_+ < \pi/2$  and  $V(\varphi_+) = E$ . It follows from the description of the solutions of the conservative Newtonian system in Subsection 3.3, that if  $V'(\varphi_+) \neq 0$ , then every solution with energy  $E$  which starts in the interval  $] - \pi/2, \varphi_+[$  falls flat in a finite time. In Subsection 3.3 we also have described which solutions fall flat in a finite time when  $V'(\varphi_+) = 0$ .

We note that the bifurcation analysis in the papers of Fedorov [8], Cushman, Hermans and Kemppainen [5], and O'Reilly [13] shows that if  $(\bar{\sigma}_3, \bar{\sigma}_4) \in l_- \setminus \{0\}$  is not too far away from the

origin, then  $V < E$  also has a connected component  $I$  which does not have  $-\pi/2$  as a boundary point. Because there are solutions  $\varphi(t)$  which oscillate back and forth in  $I$ , not all solutions with  $(\bar{\sigma}_3, \bar{\sigma}_4) \in l_- \setminus \{0\}$  fall flat in a finite time in this case.

Replacing  $\varphi$  by  $-\varphi$ , we can draw similar conclusions about falling flat when  $(\bar{\sigma}_3, \bar{\sigma}_4) \in l_+ \setminus \{0\}$ . If  $(\bar{\sigma}_3, \bar{\sigma}_4) \in l_- \cap l_+$ , then  $\bar{\sigma}_3 = \bar{\sigma}_4 = 0$ , and we are in the special case of the falling disk which has been discussed in Subsection 3.4.

If we consider  $(\bar{\sigma}_3, \bar{\sigma}_4)$  as a map from the unreduced phase space to  $\mathbf{R}^2$ , then the pre-image  $L_{\pm}$  of  $l_{\pm}$  under this mapping is an analytic hypersurface in the unreduced phase space. Let  $F$  be the set of initial data in the unreduced phase space of all the motions of the disk which fall flat in a finite time, mentioned in the introduction. It follows from the above considerations that  $F$  is a semi-analytic subset of the phase space, that is, a subset which is determined by equalities and inequalities involving analytic functions.  $F$  is contained in  $L_+ \cup L_-$  and contains a non empty open subset of  $L_+ \cup L_-$ , and therefore  $F$  has codimension equal to one. This proves the statement in Section 1 that  $F$  is a codimension one semi-analytic subset of the phase space. We find it quite surprising that the set of initial data such that the disk falls flat has such a high dimension.

### 6.3. Limiting behaviour when falling flat

In this subsection we discuss the limiting behaviour of the disk when it falls flat. Up until now we have only considered the angle  $\varphi$  between the oriented plane of the rim and the vertical direction. Here we treat other aspects of the motion.

**Proposition 1.** *Assume that the disk falls flat or rises up from the flat position when  $t \uparrow t_*$  or  $t \downarrow t_*$ . Then the disk falls onto or rises from the flat position with a bang in the sense that  $\dot{\varphi}(t)$  has a nonzero limit as  $t \rightarrow t_*$ . Moreover, the solution in the unreduced phase space and the point of contact converge as  $t \rightarrow t_*$ . Also the vector  $\dot{u}(t)$  converges to a nonzero vector in the horizontal plane as  $t \rightarrow t_*$ .*

*Proof.* Since the disk falls flat as  $t \rightarrow t_*$ , we know that  $u(t) \rightarrow \pm e_3$ . Suppose that  $u \rightarrow -e_3$ . This corresponds to  $\varphi \rightarrow -\pi/2$  or equivalently  $\sigma_1 \downarrow -1$  as  $t \rightarrow t_*$ . In other words, we have assumed that  $(\bar{\sigma}_3, \bar{\sigma}_4) \in l_-$ . The condition  $\varphi \rightarrow -\pi/2$  means that the energy  $E$  of the solution is greater than  $V(-\pi/2)$ . Because  $E = \frac{1}{2}\dot{\varphi}^2 + V(\varphi)$  is constant, using Lemma 4 we find that

$$\dot{\varphi} \rightarrow \dot{\varphi}_* := \pm((2/M)(E - V(-\pi/2))^{1/2} \neq 0 \quad \text{as } t \rightarrow t_*. \quad (6.12)$$

The minus sign holds in the above limit when the disk falls flat and the plus sign when it rises from the the flat position. Because  $\sigma_1 = \sin \varphi$ , we get  $\sigma_2 = \dot{\sigma}_1 = (\cos \varphi) \dot{\varphi} = (1 - \sigma_1^2)^{1/2} \dot{\varphi}$ , which implies

$$(1 - \sigma_1^2)^{-1/2} \sigma_2 \rightarrow \dot{\varphi}_* \quad \text{as } t \rightarrow t_*. \quad (6.13)$$

The condition that  $(\bar{\sigma}_3, \bar{\sigma}_4) \in l_-$  implies  $X r'(0) - Y r(0) = 0$ , see (6.1) and (6.5), which in view of (5.5) implies  $\sigma_3(\sigma_1; \bar{\sigma}_3, \bar{\sigma}_4) = \bar{\sigma}_3 r(\sigma_1)/r(0)$  and therefore, in view of the first equation in (3.1),

$$\sigma_4(\sigma_1; \bar{\sigma}_3, \bar{\sigma}_4) = -\frac{I_1}{I_3} \frac{d\sigma_3}{d\sigma_1} = -\frac{I_1 \bar{\sigma}_3}{I_3 r(0)} r'(\sigma_1).$$

Because  $r(\sigma_1)$  is analytic in a neighborhood of  $\sigma_1 = -1$  with  $r(-1) = 0$  and  $r'(-1) = 1$ , we have

$$\sigma_3/(1 + \sigma_1) \rightarrow \bar{\sigma}_3/r(0) \quad \text{as } t \rightarrow t_* \quad (6.14)$$

and

$$\sigma_4 \rightarrow (\sigma_4)_* := -I_1 \bar{\sigma}_3/I_3 r(0) \quad \text{as } t \rightarrow t_*. \quad (6.15)$$

If we combine (2.22) with the above two limits we find that

$$\dot{\psi} \rightarrow \left(-\frac{1}{2} + \frac{I_1}{I_3}\right) \frac{\bar{\sigma}_3}{r(0)} \quad \text{as } t \rightarrow t_*. \tag{6.16}$$

Here  $\psi$  is the angle of the horizontal part of the vector  $u$ , see (2.21), and  $\dot{\psi}(t) = d\psi(t)/dt$ . Note that the limit in (6.16) is equal to zero when all the mass is concentrated in the plane of the rim, see (2.4). Because  $\psi(t)$  is obtained from  $\dot{\psi}(t)$  by means of an integration over  $t$ , it follows that  $\psi(t)$  converges to an angle  $\psi_*$  when  $t \rightarrow t_*$ . Differentiating (2.21) with respect to time, we obtain

$$\dot{u} \rightarrow \dot{\varphi}_* (\cos \psi_*, \sin \psi_*, 0) \neq 0 \quad \text{as } t \rightarrow t_*. \tag{6.17}$$

Here we have used the convergence of  $\dot{\varphi}$ , see (6.12), the convergence of  $\dot{\psi}$ , and  $\varphi \rightarrow -\pi/2$ .

Combining (2.20) with (6.13), (6.14), and (6.15), we find that

$$\omega_1 \rightarrow -\dot{\varphi}_* \sin \psi_*, \quad \omega_2 \rightarrow \dot{\varphi}_* \cos \psi_*, \quad \omega_3 \rightarrow (\sigma_4)_* \quad \text{as } t \rightarrow t_*. \tag{6.18}$$

In view of  $\dot{u} = u \times \omega$ , see (2.13), this reconfirms (6.17).

Because  $A(t)$  is obtained by solving the ordinary differential equation (2.1) on  $SO(3)$ , where  $\omega(t)$  converges to (6.18) as  $t \rightarrow t_*$ , it follows that  $A(t)$  converges to an element  $A_*$  of  $SO(3)$  as  $t \rightarrow t_*$ . The position  $a(t)$  of the center of mass of the disk is obtained by integrating the equation (2.11), whose right hand side converges. Therefore  $a(t)$  converges to some element  $a_* \in \mathbf{R}^3$  as  $t \rightarrow t_*$ . Therefore the solution in the unreduced phase space converges as  $t \rightarrow t_*$ . Finally, equation (2.34) implies that the point of contact  $p(t)$  satisfies

$$p(t) \rightarrow p_* = -r A_* (\cos \psi_*, \sin \psi_*, 0) + a_* \quad \text{as } t \rightarrow t_*. \tag{6.19}$$

The case when  $\sigma_1 \uparrow 1$ , that is,  $(\bar{\sigma}_3, \bar{\sigma}_4) \in l_+$ , follows by applying the symmetry  $(\sigma_1, \bar{\sigma}_3, \bar{\sigma}_4) \mapsto (-\sigma_1, -\bar{\sigma}_3, \bar{\sigma}_4)$  or the symmetry  $(\sigma_1, \bar{\sigma}_3, \bar{\sigma}_4) \mapsto (-\sigma_1, \bar{\sigma}_3, -\bar{\sigma}_4)$ . ■

According to (6.18), the angular velocity vector  $\omega$  in body coordinates converges when the disk falls flat. It follows also from (6.18) that the length of the horizontal component of the limit of this angular velocity is equal to  $|\dot{\varphi}| > 0$ . Moreover, the limiting direction of  $\omega$  is perpendicular to the limit of  $u$ . This means that as  $t \rightarrow t_*$ , the motion converges to a rotation about an axis through the limiting point of contact  $p_*$ . This axis lies in the vertical plane which is tangent to the rim of the disk. The vertical component of the limiting angular velocity is  $(\sigma_4)_* = -I_1 \bar{\sigma}_3 / I_3 r(0)$ , which is nonzero as soon as  $\bar{\sigma}_3 \neq 0$ . Because  $\bar{\sigma}_4$  is proportional to  $\bar{\sigma}_3$  on  $l_{\pm}$ , see (6.1), the condition  $\bar{\sigma}_3 \neq 0$  is equivalent to  $(\bar{\sigma}_3, \bar{\sigma}_4) \neq (0, 0)$ . In other words, we are not in the special case of falling flat described in Subsection 3.4. Thus, at the same time as the disk is rotating about a horizontal axis, when it falls flat, it is also spinning about its vertical symmetry axis, with an angular speed equal to  $(\sigma_4)_*$ . The limiting point of contact  $p_*$ , see (6.19), acts as a hinge point in the sense that it lies on the axis about which the disk is rotating when it falls flat. We have proved all the statements in Section 1 about the limiting motion when the disk falls flat.

## 7. Near falling flat

In this section we investigate the asymptotic behaviour of the solutions for which  $p = (\bar{\sigma}_3, \bar{\sigma}_4) \notin l_{\pm}$  approaches a point  $q \in l_{\pm}$ . In other words, we look at solutions for which the disk does not fall flat and which are close to solutions for which the disk falls flat in a finite time. For  $\sigma_1$  bounded away from  $\pm 1$ , the potential function  $V_p(\sigma_1)$  is close to  $V_q(\sigma_1)$ . Accordingly, the solutions of the Newtonian system 3.11 and also the reconstructed solutions are close to each other, see Subsections 3.3 and 2.4. However, when  $\sigma_1$  is close to  $\pm 1$ , the motions differ greatly, because  $V_p(\sigma_1) \rightarrow \infty$  as  $\sigma_1 \rightarrow \pm 1$ , see (6.3), whereas  $\varphi \mapsto V_q(\sin \varphi)$  has an analytic extension to a neighborhood of  $\varphi = \pm\pi/2$ , see Lemma 4.

### 7.1. Elastic reflection of the angle $\varphi$

The next lemma implies that as  $\eta_{\pm} \rightarrow 0$ , the motion of  $\varphi(t)$  converges to a motion in a potential well, with the potential function as given in Lemma 4, together with a vertical wall at  $\varphi = \pm\pi/2$ , at which we have an elastic reflection. Such an elastic collision is mentioned in O'Reilly [13]-Sec. 5, although not as the consequence of an asymptotic analysis of nearly flat falling disks. All the asymptotic statements in the lemma are for  $\eta_{\pm} \rightarrow 0$ . They are locally uniform in  $\bar{\sigma}_3$  and the energy  $E$ , where we assume that  $E > V_q(\pm 1)$  and  $V_q(\pm 1)$  is given by (6.9).

**Lemma 5.** *Let  $K$  be a bounded subset of  $\mathbf{R}$ . Let  $q = (\bar{\sigma}_3^0, \bar{\sigma}_4^0)$  with  $\bar{\sigma}_4^0 = \pm I_1 r'(0) \bar{\sigma}_3^0 / (I_3 r(0))$  be the point on  $l_{\pm}$  which is parametrized by  $\bar{\sigma}_3^0 \in K$ , see (6.1). Assume that  $p = (\bar{\sigma}_3, \bar{\sigma}_4) \notin l_{\pm}$  is close to  $q$ . That is,  $0 < |\eta_{\pm}| \ll 1$ . Finally suppose that  $\sigma_1 = \sin \varphi$  is close to  $\pm 1$ .*

*If  $V_q(\pm 1) < V_p(\sigma_1) \leq E$  and  $V_p(\sigma_1)$  is not close to  $V_q(\pm 1)$ , then  $\cos \varphi$  is of order  $|\eta_{\pm}|$ . In addition, during the time interval of order  $|\eta_{\pm}|$  where  $V_p(\sigma_1)$  is not close to  $V_q(\pm 1)$ , the time derivative  $\dot{\varphi}(t)$  changes monotonically from a value close to  $\pm A$  to its negative. Here*

$$A := (2(E - V_q(\pm 1)))^{1/2} (I_1 + m r^2)^{-1/2}. \quad (7.1)$$

*Proof.* We use the notation of the proof of Lemma 3. This time we have two small variables:  $\epsilon$  and  $1 \mp z$ . Because  $r(z) \ln(1+z) \sim (1+z) \ln(1+z)$  and  $w(z) \sim 1$  as  $z \downarrow -1$ , we have  $x(z) \sim a(1 \mp z) + \epsilon$  as  $z \rightarrow \pm 1$ .

Since  $r'(z) \sim 1$ ,  $r(z)/(1+z) \sim 1$ , and  $w'(z) = O(1)$  as  $z \downarrow -1$ , we have  $y(z) = x'(z) \sim \mp \{a + \epsilon(c/2) \ln(1 \mp z)\}$  as  $z \rightarrow \pm 1$ . It follows that

$$\begin{aligned} W_{X,Y} &\sim \frac{d}{4(1 \mp z)} (a(1 \mp z) + \epsilon)^2 + \frac{1}{2} \left( a + \frac{c}{2} \epsilon \ln(1 \mp z) \right)^2 + (2(1 \mp z))^{1/2} \\ &\sim \frac{d}{4} \frac{\epsilon^2}{1 \mp z} + \frac{1}{2} a^2 + \frac{1}{2} a c \epsilon \ln(1 \mp z), \end{aligned}$$

where we have deleted all terms which are small. Among these is the term  $(c^2/8)\epsilon^2 \ln^2(1 \mp z)$  which is small compared to  $(d/4)\epsilon^2/(1 \mp z)$ . If  $\epsilon^2/(1 \mp z)$  is small, then  $1 \mp z \gg \epsilon^2$  and therefore  $|\epsilon \ln(1 \mp z)| \ll |\epsilon \ln(\epsilon^2)| \ll 1$ . Hence  $W_{X,Y} - a^2/2$  is *not* small but is bounded, only if  $1 \pm z$  is of the same order as  $\epsilon^2$ . In this situation we have

$$x(z) \sim \epsilon \quad \text{and} \quad y(z) \sim \mp a, \quad (7.2)$$

because  $\epsilon \ln(1 \mp z)$  is small. Therefore  $W_{X,Y} \sim a^2/2 + (d/4)\epsilon^2/(1 \mp z)$ . Since  $z = \sigma_1 = \sin \varphi$  is close to  $\pm 1$ , using (6.11) we see that

$$\cos \varphi \quad \text{is of the same order as} \quad |\epsilon|, \quad (7.3)$$

and

$$W_{X,Y} \sim \frac{a^2}{2} + \frac{d\epsilon^2}{2\cos^2 \varphi}. \quad (7.4)$$

In order to estimate the derivative  $V'(\varphi) = dV_p(\sin \varphi)/d\varphi = V_p'(\sin \varphi) \cos \varphi$  of the potential function  $V : \varphi \mapsto V_p(\sin \varphi)$ , we substitute  $x(z) \sim a(1 \mp z) + \epsilon$  and  $y(z) \sim \mp \{a + \epsilon(c/2) \ln(1 \mp z)\}$  into (4.10), and get

$$\begin{aligned} W'_{X,Y} &\sim (1/2)(a + \epsilon/(1 \mp z)) [\pm d(1/2)(a + \epsilon/(1 \mp z)) \mp (d+c)(a + \epsilon(c/2) \ln(1 \mp z))] \\ &\quad \mp (2(1 \mp z))^{-1/2} \end{aligned} \quad (7.5)$$

If we use that  $1 \mp z$  is of the same order as  $\epsilon^2$ , then (7.5) and (6.11) imply that

$$(\cos \varphi) W'_{X,Y} \sim \pm d \epsilon^2 \cos^3 \varphi. \quad (7.6)$$

In view of (7.3) we conclude that  $\pm V'(\varphi)$  is positive and of the same order as  $1/|\epsilon|$ . Using Newton's equation of motion (3.11) we conclude that  $\mp \ddot{\varphi}$  is positive and of the same order as  $1/|\epsilon|$ , during the time interval that  $V_p(\sigma_1)$  is not close to  $V_q(\pm 1)$ . From the expression (3.9) for the energy we see that this is the time interval when  $\dot{\varphi}$  is not close to  $\pm A = \pm[(2/M)(E - V_q(-1))]^{1/2}$ . Let  $\tau$  be the time needed for  $\dot{\varphi}$  to run from close  $\pm A$  to close to  $\mp A$ . Then  $\pm 2A \sim \dot{\varphi}(\tau) - \dot{\varphi}(0) = \int_0^\tau \ddot{\varphi}(t) dt$  is of the same order as  $\tau/|\epsilon|$ . Thus  $\tau$  is of the same order as  $|\epsilon|$ , and therefore of the same order as  $|\eta_\pm|$ . This proves the lemma. ■

If  $p \notin l_\pm$  is close to  $q \in l_\pm$  and the energy  $E > V_q(\pm 1)$  is close to  $V_q(\pm 1)$ , then  $\varphi(t)$  stays close to  $\pm\pi/2$ . If in addition we take  $|\eta_\pm| > 0$  sufficiently small in comparison to  $E - V_q(\pm 1)$ , then for most of the time  $\ddot{\varphi} = -\partial V_p(\sin \varphi)/\partial \varphi \sim -\partial V_q(\sin \varphi)/\partial \varphi \sim \pm mgr$ , see (6.10). If we start at the point where  $\varphi(0)$  is farthest away from  $\pm\pi/2$ , where  $V_p(\varphi(0)) = E$  and  $\dot{\varphi}(0) = 0$ , then  $\dot{\varphi}(t) \sim \pm mgrt$ , until  $\varphi(t) \sim \pm\pi/2$ , where  $\dot{\varphi}(t) \sim \pm((2/M)(E - V_q(\pm 1)))^{1/2}$ , see (3.9). The period (3.13) of the periodic solution of the Newtonian system (3.11), that is, the time needed for  $\varphi(t)$  to go to the nearest  $\pm\pi/2$  and return to its initial value, is asymptotically equal to

$$2^{3/2} (I_1 + m r^2)^{-1/2} (mgr)^{-1} (E - V_q(\pm 1))^{1/2}.$$

Here we first let  $\eta_\pm \rightarrow 0$  and then  $E \downarrow V_q(\pm 1)$ . The fact that this period goes to zero, that is, the frequency of the oscillations in  $\varphi(t)$  goes to infinity, is quite uncommon for oscillations in a potential well.

If  $\eta_\pm \rightarrow 0$ , then the motion of  $\varphi(t)$  converges to that of the conservative Newton system (3.11) with  $(\bar{\sigma}_3, \bar{\sigma}_4) = q \in l_\pm$  together with condition that we have an elastic reflection  $\dot{\varphi} \mapsto -\dot{\varphi}$  when  $\varphi(t) = \pm\pi/2$ . For  $E > V_q(\pm 1)$  and  $E$  close to  $V_q(\pm 1)$ , the motion of  $\varphi(t)$  resembles that of a ball which is dropped on the floor and bounces back up elastically, where the frequency of the bouncing tends to infinity as the height from which the ball falls goes to zero.

### 7.2. The increase of the angles $\psi$ and $\chi$

In order to reconstruct the motion of the disk during the the short time of order  $|\eta_\pm|$  that  $V_p(\sigma_1)$  differs markedly from  $V_q(\sigma_1)$ , we look at the behaviour of the angles  $\chi$  and  $\psi$  in (2.30) and (2.21), respectively. Lemma 6 and Proposition 2 below imply that they increase very rapidly from an initial limiting value to a finite limit value, by an amount which in absolute value is equal to the constant  $\Delta\chi$  in (7.9). The sign of  $\Delta\chi$  depends on the side of  $l_\pm$  from which  $p \notin l_\pm$  approaches the point  $q \in l_\pm$ .

**Lemma 6.** *We retain the assumptions in Lemma 5. If  $\cos \varphi \ll |\eta_\pm|^{1/2}$ , then the time derivatives of  $\chi(t)$  and  $\psi(t)$  are asymptotically equal to*

$$\dot{\chi} \sim \eta_\pm / (I_1 \cos^2 \varphi) \quad \text{and} \quad \dot{\psi} \sim \pm \eta_\pm / (I_1 \cos^2 \varphi), \tag{7.7}$$

which in turn are of the order  $\pm 1/|\eta_\pm|$  and  $1/|\eta_\pm|$ , respectively. However, the change in  $\chi(t)$  and  $\psi(t)$  is small over any time interval during which  $1 \gg \cos \varphi(t) \gg |\eta_\pm|$ .

*Proof.* According to (2.31) we have  $\dot{\chi} = \sigma_3 / (1 - \sigma_1^2) = \sigma_3 / \cos^2 \varphi$ . It follows from (6.11) and the beginning of the proof of Lemma 5 that  $x \sim a(1 \mp z) + \epsilon \sim (a/2) \cos^2 \varphi + \epsilon$ . This implies  $\sigma_3 / \cos^2 \varphi = -I_3 b x / (I_1 \cos^2 \varphi) \sim -I_3 b \epsilon / (I_1 \cos^2 \varphi) = \eta_\pm / (I_1 \cos^2 \varphi)$ , as long as  $\cos \varphi \ll |\epsilon|^{1/2}$ , see (4.1) and the beginning of the proof of Lemma 3. This shows that (7.7), provided  $\cos \varphi \ll |\eta_\pm|^{1/2}$ .

If  $\cos \varphi \gg |\epsilon|$ , then (7.4) implies that  $V_p(\sin \varphi) \sim V_q(\pm 1)$ . Therefore  $\dot{\varphi} = \pm((2/M)(E - V(\varphi)))^{1/2} \sim \pm((2/M)(E - V_q(\pm 1)))^{1/2}$  remains bounded away from zero. Here, as in the beginning of Subsection 3.3, we have written  $V(\varphi) = V_p(\sin \varphi)$ . As long as  $|\epsilon|^{1/2} \gg \cos \varphi \gg |\epsilon|$ ,

$$\chi(t_1) - \chi(t_0) = \int_{t_0}^{t_1} \dot{\chi}(t) dt = \int_{\varphi(t_0)}^{\varphi(t_1)} \sigma_3(\varphi) (\cos \varphi)^{-2} ((2/M)(E - V(\varphi)))^{-1/2} d\varphi \tag{7.8}$$

is of the same order as  $|\epsilon|/\cos\varphi \ll 1$ . This follows from the fact that  $\sigma_3(\varphi)$  and  $(E - V(\varphi))^{-1/2}$  remain bounded and the fact that the substitution of variables  $\gamma = \cos\varphi$  shows that (7.8) is of the order of  $\int_{\gamma_0}^{\gamma_1} \gamma^{-2} d\gamma = \gamma_0^{-1} - \gamma_1^{-1}$ . If  $1 \gg \cos\varphi$  and  $|\epsilon| = O(\cos^2\varphi)$ , then  $\sigma_3 = -(I_3/I_1)bx = O(\cos^2\varphi)$ . Therefore  $\dot{\chi} = \sigma_3/\cos^2\varphi = O(1)$ , and the change in  $\chi(t)$  is small during the small time interval when  $\cos\varphi(t)$  remains small.

The statements about  $\psi(t)$  follow because (2.22) implies that  $\dot{\psi} = (1 - \sigma_1^2)^{-1} \sigma_1 \sigma_3 - \sigma_4 \sim \pm \sigma_3/\cos^2\varphi$ . Here we have used the facts that  $\sigma_1 = \sin\varphi \sim \pm 1$  and  $\sigma_4$  remains bounded in view of (2.19). This proves the lemma.  $\blacksquare$

The next proposition implies that, during the motion which approximates the elastic reflection described in Lemma 5, the angles  $\chi$  and  $\psi$  have an increase which converges to  $\text{sgn } \eta_{\pm} \Delta\chi$  and  $\pm \text{sgn } \eta_{\pm} \Delta\chi$ , respectively. Here

$$\Delta\chi := (1 + mr^2/I_1)^{1/2} \pi. \quad (7.9)$$

Note that  $\Delta\chi$  is greater than  $\pi$ . It depends only on the ratio  $mr^2/I_1$ , but *not* on the initial conditions of the solution. For the uniform disk and for the hoop we have  $\Delta\chi = \sqrt{5}\pi$  and  $\Delta\chi = \sqrt{3}\pi$ , see (2.5) and (2.6), respectively.

**Proposition 2.** *Let  $0 < \mu < \nu$  be positive constants. Consider the solutions with the constants of motion  $p = (\bar{\sigma}_3, \bar{\sigma}_4) \notin l_{\pm}$  near  $q \in l_{\pm}$  and energy  $E \in [V_q(\pm 1) + \mu, V_q(\pm 1) + \nu]$ . Then for every  $\delta > 0$  there are numbers  $0 < \tilde{\mu} \leq \mu$  and  $\tilde{\eta} > 0$  such that if 1)  $0 < |\eta_{\pm}| \leq \tilde{\eta}$  and 2)  $[t_0, t_1]$  is a time interval such that  $V_p(\sigma_1(t))$  grows from  $V_q(\pm 1) + \tilde{\mu}$  to  $E$  and then falls back to  $V_q(\pm 1) + \tilde{\mu}$  as  $t$  traces out  $[t_0, t_1]$ , then*

$$|\chi(t_1) - \chi(t_0) - \text{sgn } \eta_{\pm} \Delta\chi| \leq \delta \quad (7.10)$$

and

$$|\psi(t_1) - \psi(t_0) - \pm \text{sgn } \eta_{\pm} \Delta\chi| \leq \delta. \quad (7.11)$$

Here  $\text{sgn } \eta_{\pm}$  is the sign of  $\eta_{\pm}$ .

*Proof.* We begin by estimating the integral in the right hand side of (7.8), where  $t_0 < t_1$  and  $\phi(t_1)$  is the angle closest to  $\pm\pi/2$ . In addition,  $V(\varphi(t_1)) = E$  and  $\cos\varphi(t_1) = O(|\epsilon|)$ , and  $\cos\varphi(t_0) \gg |\epsilon|$ . Let  $V_0 = V_q(\pm 1)$ . Then

$$(E - V(\varphi))^{-1/2} = (E - V_0)^{-1/2} (1 - [V(\varphi) - V_0]/[E - V_0])^{-1/2}. \quad (7.12)$$

It follows from  $V_p = mgrW_{X,Y}$ , see (4.8), and (7.6) that

$$V'(\varphi) \sim \pm mgrd\epsilon^2/\cos^3\varphi. \quad (7.13)$$

This implies that  $V'(\phi)$  has a constant sign. Therefore there is an analytic substitution of variables  $\varphi = \Phi(w)$  with  $w > 0$ , such that

$$[V(\varphi) - V_0]/[E - V_0] = w^2, \quad (7.14)$$

where  $\varphi(t_1) = \Phi(1)$ . From  $V_p = mgrW_{X,Y}$  and (7.4) we obtain

$$V(\varphi) - V_0 \sim mgrd\epsilon^2/2\cos^2\varphi. \quad (7.15)$$

Therefore (7.14) implies that  $w \sim C|\epsilon|/\cos\varphi$ , where  $C$  is a positive constant. Consequently,  $\varphi(t_0) = \Phi(w_0)$  where  $0 < w_0 \ll 1$ . If we differentiate (7.14) with respect to  $w$ , we obtain

$$V'(\varphi)\Phi'(w) = 2(E - V_0)w = 2(E - V_0)^{1/2}(V(\varphi) - V_0)^{1/2},$$

using (7.14) to obtain the second equation. Because (7.12) and (7.14) imply that  $(E - V(\varphi))^{-1/2} = (E - V_0)^{-1/2}(1 - w^2)^{-1/2}$ , it follows that

$$(E - V(\varphi))^{-1/2}\Phi'(w) = 2(1 - w^2)^{-1/2}(V(\varphi) - V_0)^{1/2}/V'(\varphi).$$

In view of (7.15) and (7.13) this leads to

$$\pm ((2/M)(E - V(\varphi)))^{-1/2} \Phi'(w) \sim (M/mgrd)^{1/2} ((\cos^2 \varphi)/|\epsilon|) (1 - w^2)^{-1/2}.$$

Combining the above relation with  $\sigma_3(\varphi) = -(I_3/I_1)bx \sim -(I_3/I_1)b\epsilon$  and using the fact that  $\text{sgn } \epsilon = -\text{sgn } \eta_{\pm}$ , then we see that the right hand side of (7.8) is asymptotically equal to

$$(\text{sgn } \eta_{\pm}) D \int_{w_0}^1 (1 - w^2)^{-1/2} dw \sim (\text{sgn } \eta_{\pm}) D \pi/2,$$

where  $D = M^{1/2} (mgrd)^{-1/2} (I_3/I_1)b$  and we have used that  $0 < w_0 \ll 1$ . Using  $M = I_1 + mr^2$ ,  $d = I_3^2/I_1 (I_3 + mr^2)$  and  $b = (mgr)^{1/2} (I_3 + mr^2)^{-1/2}$ , see (3.10), (4.7) and (4.5), respectively, we obtain that  $D = (1 + mr^2/I_1)^{1/2}$ .

During the time interval that  $V_p(\sigma_1(t))$  decreases from  $E$  to being close to  $V_q(\pm 1)$  we have the same increase in  $\chi(t)$ . This follows because after the reflection at  $\varphi = \pm\pi/2$ , the angle  $\varphi(t)$  performs the time reversed motion of the one during the time interval that  $V_p(\sigma_1(t))$  increases from being close to  $V_q(\pm 1)$  to  $E$ . Note that the time derivative of  $\chi(t)$  does not change sign during this reversed motion, see the estimate for  $\dot{\chi}$  in Lemma 6. The proof of the statement about the increase of  $\chi(t)$  is complete.

Again the statements about  $\psi(t)$  follow because (2.22) implies  $\dot{\psi} = (1 - \sigma_1^2)^{-1} \sigma_1 \sigma_3 - \sigma_4 \sim \pm \sigma_3 / \cos^2 \varphi$ . Here we have used the facts that  $\sigma_1 = \sin \varphi \sim \pm 1$  and  $\sigma_4$  remains bounded in view of (2.19). ■

Figure 1 contains computer pictures of the angle  $\chi(t)$  as a function of time for the uniform disk. We have chosen the initial conditions  $\sigma_1(0) = 0$ ,  $\sigma_2(0) = \dot{\sigma}_1(0) = 1$ ,  $\sigma_3(0) = \bar{\sigma}_3 = 1$ . One picture is for  $\sigma_4(0) = \bar{\sigma}_4 = (1/2)(r'(0)/r(0)) - 0.01$  and the other for  $\sigma_4(0) = \bar{\sigma}_4 = (1/2)(r'(0)/r(0)) + 0.01$ . It follows that  $(\bar{\sigma}_3, \bar{\sigma}_4)$  is close to  $l_+$ , with  $\eta_+/I_3 r(0) = 0.01$  and  $\eta_+/I_3 r(0) = -0.01$ , respectively. For  $t = 0$  the disk is in the vertical position and falling into the direction which will end up close to the flat position. We have shown the behaviour of  $\chi(t)$  during a time interval of somewhat more than three times the period  $\tau$  of the solution of the fully reduced system. Because  $d\chi(t)/dt$  is periodic with period  $\tau$ , the picture will repeat itself with a vertical shift equal to  $\chi(\tau) - \chi(0)$ .

The figures 2 and 3 depict the horizontal projection  $\cos \varphi(t) (\cos \chi(t), \sin \chi(t))$  of the vector  $v = v(t)$  in (2.23). because the disk starts in the vertical position, the curve starts on the boundary circle, in the upper right quadrant with our choice of  $\chi(0)$ . Close to the origin, when  $\cos \varphi(t)$  is small, the curve runs around the origin in the positive and negative direction, over an angle close to  $\sqrt{5}\pi > 2\pi$ , if  $\eta_+ > 0$  and  $\eta_+ < 0$ , respectively. This is shown in the enlargements to the right. We have showed only about 1.4 period, because otherwise the behaviour near the origin, which just repeats itself at a different angle, would become difficult to discern. The fact that the disk in the vertical initial position is falling implies that after it has risen again it will swing past the vertical position, which means that the vector  $v$  makes an excursion into the other hemisphere, where the equator is marked in Fig. 3 as the outer circle. At the moment when it returns to the outer circle, the solution of the fully reduced system has completed one period.

In Figs. 4 and 5 the same is repeated for the hoop, when close to the origin the curve runs around the origin in the positive and negative direction, over an angle close to  $\pi < \sqrt{3}\pi < 2\pi$  if  $\eta_+ > 0$  and  $\eta_+ < 0$ , respectively.

### 7.3. Motions near falling flat

In this subsection we describe some further aspects of the motions of the disk which are near those where it falls flat.

The total energy  $E = \mathcal{T} + \mathcal{V}$  is a constant of motion. Because (2.2) implies that  $\mathcal{T} \geq (1/2) \langle I\omega, \omega \rangle$  and (2.7) implies that  $\mathcal{V} \geq 0$ , we have  $\langle I\omega, \omega \rangle \leq 2E$ . Therefore the angular velocity vectors  $\omega$  and  $\nu = A\omega$  in body coordinates and space coordinates, respectively, remain bounded during the short

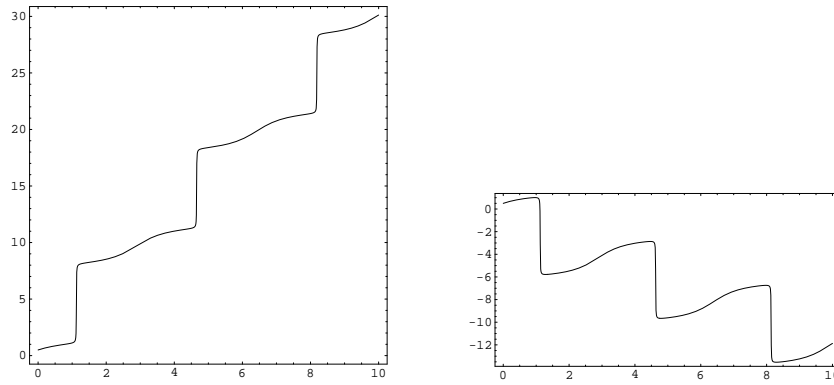

Fig. 1. The angle  $\chi(t)$  during several periods for the uniform disk, with  $0 < \eta_+ \ll 1$  (left) and  $-1 \ll \eta_+ < 0$  (right).

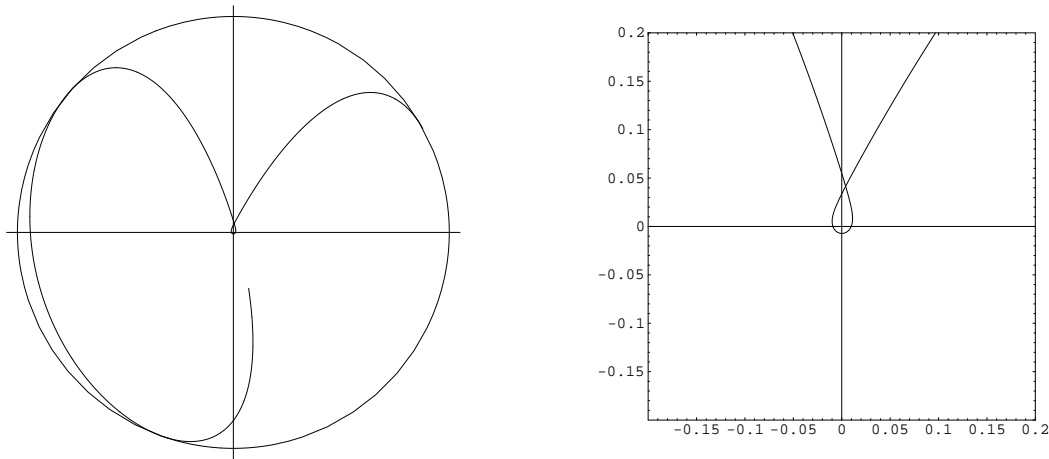

Fig. 2. The horizontal projection of  $A(t)e_3$  for the uniform disk, during 1.4 period, with  $0 < \eta_+ \ll 1$ . Zoom in (right picture) near the origin in the left picture.

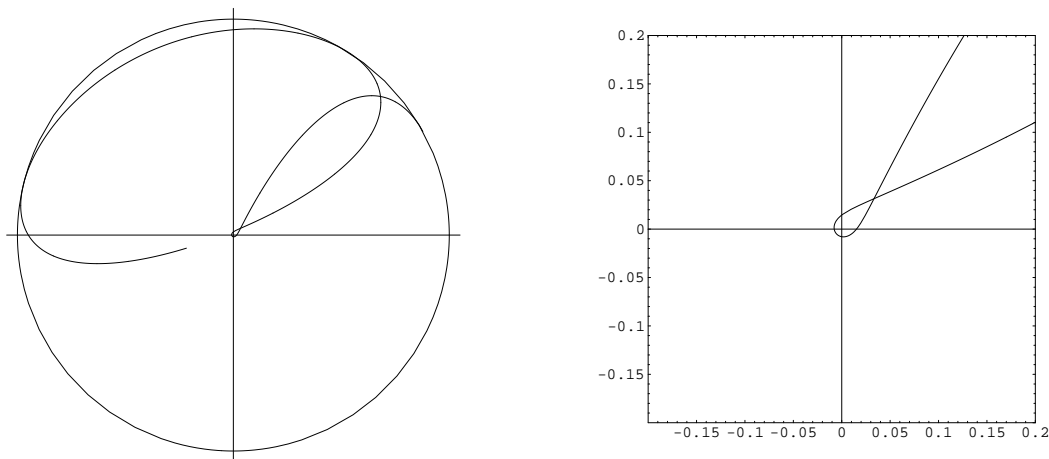

Fig. 3. The horizontal projection of  $A(t)e_3$  for the uniform disk, during 1.4 period, with  $-1 \ll \eta_+ < 0$ . Zoom in (right picture) near the origin in the left picture.

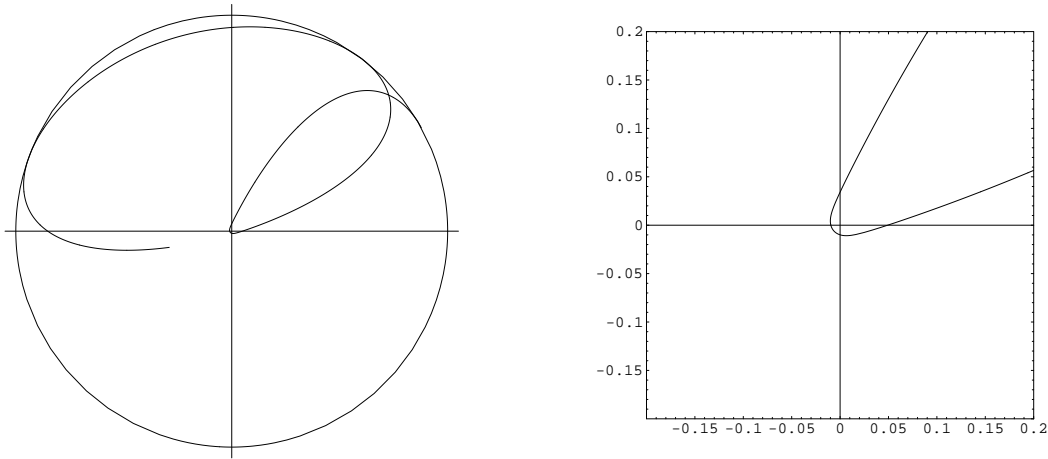

Fig. 4. The horizontal projection of  $A(t) e_3$  for the hoop, during 1.4 period, with  $0 < \eta_+ \ll 1$ . Zoom in (right picture) near the origin in the left picture.

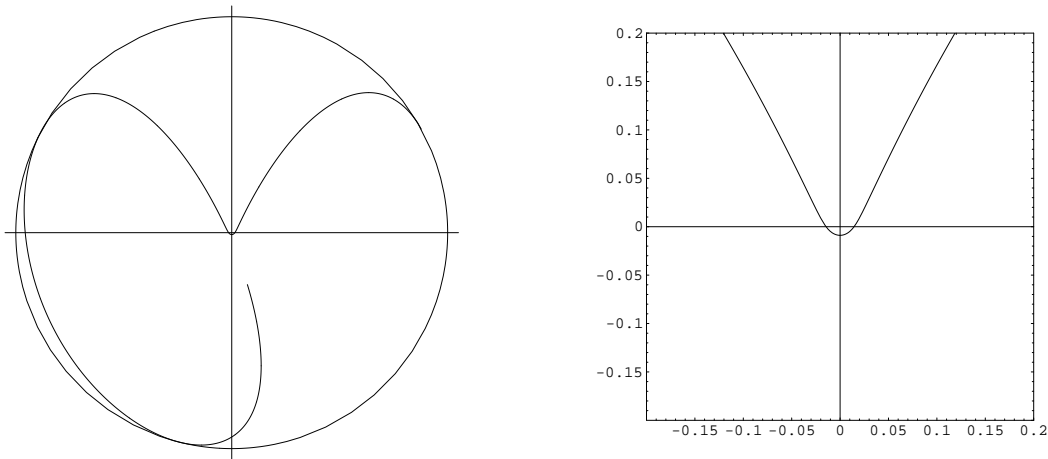

Fig. 5. The horizontal projection of  $A(t) e_3$  for the hoop, during 1.4 period, with  $-1 \ll \eta_+ < 0$ . Zoom in (right picture) near the origin in the left picture.

time interval that the rim of the disk is close to the horizontal position. From (2.1) or (2.24) it follows that the rotational motion  $A(t)$  of the near flat falling disk, during the time interval from the moment that the disk rises from close to the horizontal position until it falls close to the horizontal position, converges to the rotational motion of the disk falling flat, as described in Subsection 6.3.

For  $q \in l_{\pm}$  the solution is not defined for  $t \geq t_*$  if  $t_*$  is the instant at which the disk has fallen flat. However, the nearby solutions, for  $p \notin l_{\pm}$  but near  $q$ , exist for all time – rising up from being nearly flat after having fallen down to being nearly flat, and repeating this periodically for all time. In order to understand the limiting behaviour of the rotational motion for all time, we look at the angular velocity  $\nu(t)$  in space coordinates as  $\eta_{\pm} \rightarrow 0$ .

**Lemma 7.** *We make the same hypotheses as in Lemma 5. In addition, suppose that for  $\eta_{\pm} = 0$  the disk falls flat as  $t \uparrow t_*$  and rises from the flat position as  $t \downarrow t_*$ . Let  $\chi(t)$  and  $\nu(t)$  be the angle and angular velocity defined in (2.30) and (2.24), respectively. When  $\eta_{\pm} \neq 0$  but  $\eta_{\pm} \rightarrow 0$ , then  $\chi(t) \rightarrow \chi_{\downarrow}$  and  $\nu(t) \rightarrow \nu_{\downarrow}$  as  $t \uparrow t_*$ , whereas  $\chi(t) \rightarrow \chi_{\uparrow}$  and  $\nu(t) \rightarrow \nu_{\uparrow}$  as  $t \downarrow t_*$ . Moreover, these limiting values*

satisfy

$$\chi_{\uparrow} - \chi_{\downarrow} = (\operatorname{sgn} \eta_{\pm}) \Delta\chi, \quad (7.16)$$

$$\nu_{\downarrow} = (\pm A \sin \chi_{\downarrow}, \mp A \cos \chi_{\downarrow}, B), \quad (7.17)$$

$$\nu_{\uparrow} = (\mp A \sin \chi_{\uparrow}, \pm A \cos \chi_{\uparrow}, B), \quad (7.18)$$

where  $A$  is defined in (7.1) and

$$B := \frac{I_1 \bar{\sigma}_3}{I_3 r(0)}. \quad (7.19)$$

*Proof.* Equation (7.16) comes from (7.10).

Consider the situation when the disk is close to being flat, but  $|\eta_{\pm}| \ll \cos^2 \varphi \ll 1$ . That is, when  $|\epsilon| \ll 1 \pm z \ll 1$ , see (6.11). Then the disk is *not* in the small time interval when the angle  $\chi$  increases by order 1, as described in Proposition 2. We have  $x(z) \sim a(1 \mp z) = O(1 - z^2)$  and  $y(z) \sim \mp a$ . In view of (4.1) this implies that  $\sigma_3 = O(1 - \sigma_1^2)$  and

$$\sigma_4 \sim \pm I_1 \bar{\sigma}_3 / I_3 r(0) = \pm B. \quad (7.20)$$

In other words,  $\sigma_4$  is close to its limiting value (6.15) when the disk is falling flat or rising from being flat. From  $\sigma_1 = \sin \varphi$  and  $\sigma_2 = d\sigma_1/dt$ , see (2.15), it follows that  $(1 - \sigma_1^2)^{-1} \sigma_2 = \dot{\varphi} / \cos \varphi$ , which together with (2.30) leads to  $(1 - \sigma_1^2)^{-1} \sigma_2 v_1 = \dot{\varphi} \cos \chi$  and  $(1 - \sigma_1^2)^{-1} \sigma_2 v_2 = \dot{\varphi} \sin \chi$ . Let  $\chi_*$  be the limit of the angle  $\chi$  just before or just after the small time interval where  $\chi$  increases by order 1. Then from (2.29) it follows that

$$\nu \sim (\dot{\varphi} \sin \chi_*, -\dot{\varphi} \cos \chi_*, B),$$

Note that for the third coordinate we have  $\nu_3 = \sigma_3 + \sigma_1 \sigma_4 \sim \pm \sigma_4$ , see (2.27), and  $\sigma_4$  is asymptotically given by (7.20). Lemma 5 implies that just before the disk falls flat we have  $\dot{\varphi} \sim \pm A$ , which changes sign to  $\dot{\varphi} \sim \mp A$  just after the disk starts rising again. This proves the lemma. ■

As  $\eta_{\pm} \rightarrow 0$  and during the time interval that the disk is not close to the flat position, the rotational motion  $A(t)$  converges to the motion of the disk as described in Subsection 6.3. For its continuation beyond  $t = t_*$ , we use the limit relations for the angular velocity vector  $\nu(t)$  in space coordinates given in (7.17) and (7.18), where in turn we use (7.16).

**Corollary 1.** *Let  $\eta_{\pm} \rightarrow 0$ , but with a constant sign of  $\eta_{\pm}$ . Every time the disk falls flat, it rises up again with a jump in  $\nu(t)$  from  $\nu_{\downarrow}$  to  $\nu_{\uparrow}$ . Here  $\nu_{\uparrow}$  is obtained from  $\nu_{\downarrow}$  by applying the rotation about the vertical axis through the angle  $(\operatorname{sgn} \eta_{\pm}) (\Delta\chi - \pi)$ .*

In the limit the angular velocity  $\nu(t)$  in space coordinates is a continuous function of time, if and only if  $\Delta\chi = (2k + 1)\pi$ , or equivalently  $m r^2 / I_1 = 4k(k + 1)$ , for some integer  $k$ , see (7.9). Because  $m r^2 / I_1 = 4$  and  $m r^2 / I_1 = 2$  for the uniform disk and the hoop, respectively, see (2.5) and (2.6), in neither of these cases the limiting motion of  $\nu(t)$  is a continuous function of  $t$ .

The limit of the rotational motion as  $\eta_{\pm} \uparrow 0$  is equal to the limit of the rotational motion as  $\eta_{\pm} \downarrow 0$ , if and only if  $\Delta\chi = l\pi$  or equivalently  $m r^2 / I_1 = l^2 - 1$  for some integer  $l$ . This condition is weaker than the condition that the limiting motion of  $\chi(t) \in \mathbf{R}/2\pi\mathbf{Z}$  is continuous, but it still does not hold for the uniform disk or for the hoop. It holds for example when  $m r^2 / I_1 = 3$ , when  $\Delta\chi = 2\pi$ , which represents a mass distribution somewhere in between that of the uniform disk and the hoop.

We now discuss the limiting motion of the center of mass  $a(t)$ . Because  $\omega$  and  $(1 - \sigma_1^2)^{-1/2} \underline{u} = (\cos \psi, \sin \psi, 0)$  are bounded, it follows from (2.11) that  $\dot{a}$  remains bounded. Therefore the motion of  $a(t)$ , during the time interval that the disk rises up from being close to the flat position until it falls close to the flat position, converges to the motion of the center of mass of the disk falling flat as described in Subsection 6.3. In order to understand how the limit of the motion of the center of mass, which exists for all time, is a continuation of the motion of the center of mass of the flat falling disk, we investigate the limiting motion of  $\dot{a}(t)$ .

**Lemma 8.** *We use the same hypotheses as in Lemma 7. For  $\eta_{\pm} \neq 0$  and  $\eta_{\pm} \rightarrow 0$  we have  $\dot{a}(t) \rightarrow \dot{a}_{\downarrow}$  as  $t \uparrow t_*$  and  $\dot{a} \rightarrow \dot{a}_{\uparrow}$  as  $t \downarrow t_*$ . Here*

$$\begin{aligned} \dot{a}_{\downarrow} &= r(\pm B \sin \chi_{\downarrow}, \mp B \cos \chi_{\downarrow}, -A), \\ \dot{a}_{\uparrow} &= r(\pm B \sin \chi_{\uparrow}, \mp B \cos \chi_{\uparrow}, A), \end{aligned}$$

and  $A$  and  $B$  are given by (7.1) and (7.19), respectively.

*Proof.* To estimate the right hand side of (2.33), we observe that (7.20) yields  $\sigma_4 \sin \chi - \dot{\varphi} \cos \varphi \cos \chi \sim \pm B \sin \chi$  and  $-\sigma_4 \cos \chi - \dot{\varphi} \cos \varphi \sin \chi \sim \mp B \cos \chi$ . The asymptotic behaviour of the third component  $-\dot{\varphi} \sin \varphi$  follows from Lemma 5. ■

As  $\eta_{\pm} \rightarrow 0$  and during the time interval that the disk is not close to the flat position, the motion of the center of mass  $a(t)$  converges to the motion of the disk as described in Subsection 6.3. For its continuation beyond  $t = t_*$ , we use the limit relations for the velocity vector  $\dot{a}(t)$  of Lemma 8.

**Corollary 2.** *Let  $\eta_{\pm} \rightarrow 0$ , but with a constant sign of  $\eta_{\pm}$ . Every time the disk falls flat, it rises up again with a jump in  $\dot{a}(t)$  from  $\dot{a}_{\downarrow}$  to  $\dot{a}_{\uparrow}$ . Here  $\dot{a}_{\uparrow}$  is obtained from  $\dot{a}_{\downarrow}$  by applying a rotation about the vertical axis through an angle  $(\text{sgn } \eta_{\pm})(\Delta\chi)$  to the horizontal part of  $\dot{a}_{\downarrow}$  and changing the sign of the vertical part of  $\dot{a}_{\downarrow}$ .*

At  $t = t_*$  the limiting motion of the center of mass performs an elastic collision with the horizontal plane if and only if  $\Delta\chi = 2k\pi$ , or equivalently  $m r^2/I_1 = 4k^2 - 1$ , for some  $k \in \mathbf{Z}$ , see (7.9). Again this holds neither for the uniform disk nor for the hoop.

The limiting motion of the center of mass as  $\eta_{\pm} \uparrow 0$  is equal to the limiting motion of the center of mass as  $\eta_{\pm} \downarrow 0$ , if and only if  $\Delta\chi = l\pi$  for some  $l \in \mathbf{Z}$ , which is equivalent to the condition that the limit of the rotational motion for  $\eta_{\pm} \uparrow 0$  is equal to the limit of the rotational motion as  $\eta_{\pm} \downarrow 0$ . As we have observed before, this holds neither for the uniform disk, nor for the hoop.

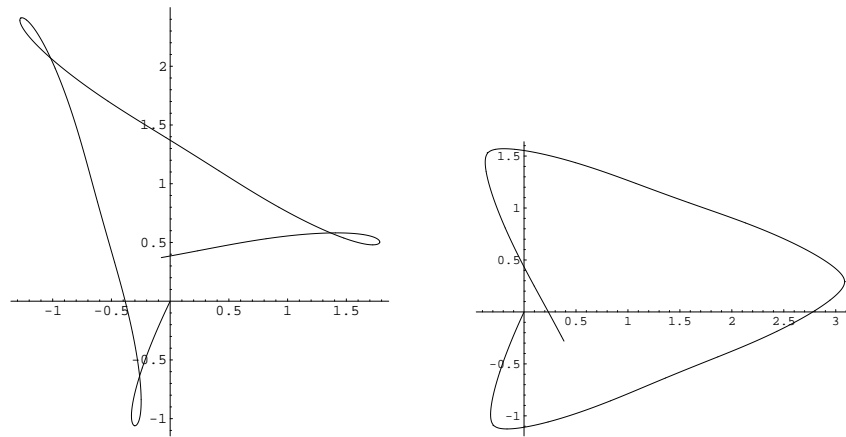

Fig. 6. The path of the horizontal projection of the center of mass of the uniform disk as in Fig. 1, with  $0 < \eta_+ \ll 1$  (left) and  $-1 \ll \eta_+ < 0$  (right).

We finally discuss the limiting motion of point of contact  $p(t)$ . If  $a_*$  denotes the limiting position of the center of mass when the disk is flat position, it follows from (2.35) and (2.30) that

$$p(t) \sim \pm r(\cos \chi(t), \sin \chi(t), 0) + a_*$$

during the small time interval that the disk is near the flat position. From Lemma 6 and Proposition 2 it follows that during this time interval the point of contact races around the rim of the disk with

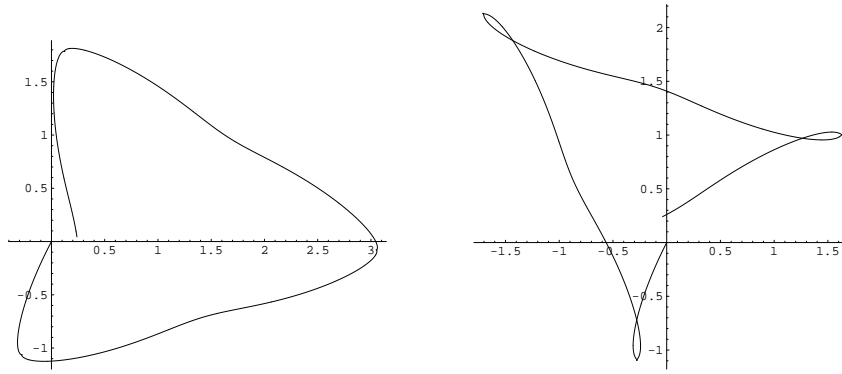

Fig. 7. The path of the horizontal projection of the center of mass of the hoop, with  $0 < \eta_+ \ll 1$  (left) and  $-1 \ll \eta_+ < 0$  (right).

a velocity of order  $1/|\eta_{\pm}|$ . During this time interval the angle of the horizontal vector  $p(t) - a_*$  increases from limiting angle  $\chi_{\downarrow} \pm \pi$ , after falling down, to the limiting angle

$$\chi_{\uparrow} \pm \pi = \chi_{\downarrow} \pm \pi + (\operatorname{sgn} \eta_{\pm}) \Delta\chi$$

before rising up, see (7.16). Note that if  $I_1 \ll mr^2$ , that is the mass of the disk is mainly concentrated near the center of mass, then the point of contact runs many times around the rim before the disk rises up again.

The point of contact has the limiting position

$$p_{\downarrow} = \pm r (\cos \chi_{\downarrow}, \sin \chi_{\downarrow}, 0) + a_*$$

after falling down, and

$$p_{\uparrow} = \pm r (\cos \chi_{\uparrow}, \sin \chi_{\uparrow}, 0) + a_*$$

when it is about to rise up. From (7.17) and (7.18) it follows that the horizontal part of  $\nu_{\downarrow}$  is orthogonal to  $p_{\downarrow} - a_*$  and the horizontal part of  $\nu_{\uparrow}$  is orthogonal to  $p_{\uparrow} - a_*$ . The orientation is such that  $p_{\downarrow}$  and  $p_{\uparrow}$  are the respective hinge points about which the disk is falling down and respectively rising up.

The vertical part  $\nu_3$  of  $\nu$ , which does not jump, represents the spinning part of the motion. It is equal to zero if and only if  $\bar{\sigma}_3 = 0$ , see (7.19). In view of  $\eta_{\pm} = 0$ , the latter condition implies that also  $\bar{\sigma}_4 = 0$ , see (6.1), which means that we are looking at the limit of solutions near the special case of falling flat of Subsection 3.4. Note that even in that case the nearby solutions exhibit the same jumps in the angles  $\chi(t)$  and  $\psi(t)$  as for all the other solutions near flat falling ones. We have proved all the statements in Section 1.

The pictures 8 and 9 illustrate the trajectories of the point of contact for the uniform disk and the hoop, respectively. The left pictures are for  $\eta_+/I_3 r(0) = 0.01$  and the right pictures are for  $\eta_+/I_3 r(0) = -0.01$ . Note the difference between the trajectories when  $\eta_+$  changes sign.

**Acknowledgement.** We are grateful to the two anonymous referees for their comments, which led to considerable improvements of the paper.

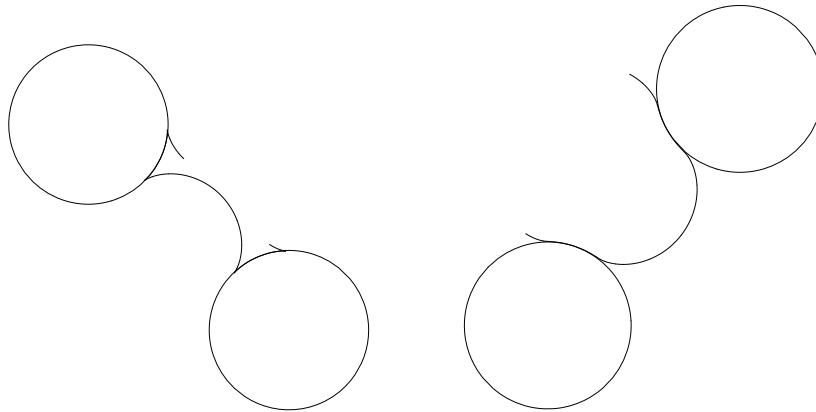

Fig. 8. The path of the point of contact of the uniform disk when  $\eta_+/(I_3 r(0)) = 0.01$  (left) and  $\eta_+/(I_3 r(0)) = 0.01$  (right).

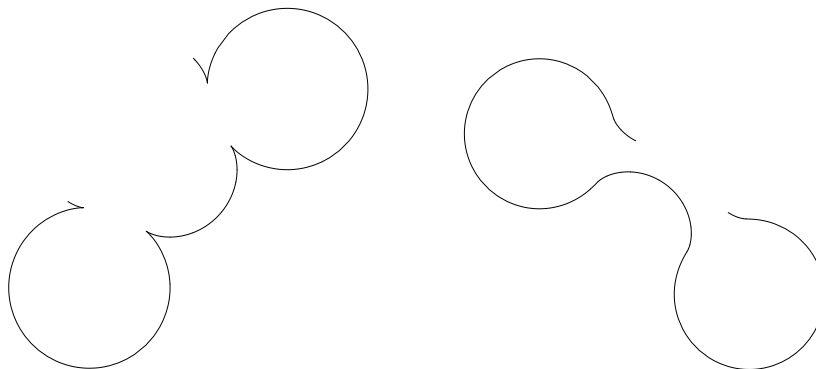

Fig. 9. The path of the point of contact for the hoop when  $\eta_+/(I_3 r(0)) = 0.01$  (left) and  $\eta_+/(I_3 r(0)) = 0.01$  (right).

## References

- [1] P. Appell. Sur l'intégration des équations du mouvement d'un corps pesant de révolution roulant par une arête circulaire sur un plan horizontal; cas particulier du cerceau. *Rendiconti del Circolo Matematico di Palermo*, **14** (1900), 1–6.
- [2] P. Appell. *Traité de la Mécanique Rationnelle*. Paris, Gauthier-Villars, 1904.
- [3] A. V. Borisov, I. S. Mamaev, A. A. Kilin. Dynamics of rolling disk. *Regul. Chaotic Dyn.*, **8** (2003), 201–212.
- [4] S. A. Chaplygin. On the motion of a heavy body of revolution on a horizontal plane. *Works of the Physical Section of the Imperial Society of Friends of Physics, Anthropology and Ethnography, Moscow*, **9** (1897), 10–16. Reproduced in: *Selected Works on Mechanics and Mathematics*. Gostehteorizdat, Moscow, 1954, 413–425. (In Russian.) A review in German see in: *Fortschritte der Mathematik*, **27** (1896), 624–625. English transl.: *Regul. Chaotic Dyn.*, **7** (2002), 119–130.
- [5] R. Cushman, J. Hermans, D. Kemppainen. The rolling disc. In: H. W. Broer, S. A. van Gils, I. Hoveijn, F. Takens (Eds.). *Nonlinear Dynamical Systems and Chaos (Groningen, 1995)*. Progress in Nonlinear Differential Equations and Their Applications, Vol. 19. Birkhäuser Verlag, Basel, Switzerland, 1996, 21–60.
- [6] E. A. Coddington, N. Levinson. *Theory of Ordinary Differential Equations*. McGraw-Hill, New York, Toronto, London, 1955.
- [7] E. T. Copson. *An Introduction to the Theory of Functions of a Complex Variable*. Oxford University Press, Oxford, 1935.

- [8] Yu. N. Fedorov. Rolling of a disc over an absolutely rough plane. *Izv. Akad. Nauk SSSR, Mekh. Tv. Tela*, **22** (1987), 67–75. English transl.: *Mechanics of Solids*, (Allerton Press, ISSN 0025–6544) **22** (1987), 65–73.
- [9] S. N. Kolesnikov. On rolling of disk on horizontal plane. *Mosk. Univ. Ser. I Mat. Mekh.*, **2** (1985), 55–60. (In Russian)
- [10] D. J. Korteweg. Ueber eine ziemlich verbreitete unrichtige Behandlungsweise eines Problems der rollende Bewegung, über die Theorie dieser Bewegung, und ins besondere über kleine rollende Schwingungen um eine Gleichgewichtslage. *Nieuw Archief voor Wiskunde*, **4** (1899), 130–155.
- [11] D. J. Korteweg. Extrait d’une lettre à M. Appell. *Rendiconti del Circolo Matematico di Palermo*, **14** (1900), 7–8.
- [12] J.-L. Lagrange. *Mécanique Analytique*. First edition 1788 in Paris. Revised and annotated reprint. A. Blanchard, Paris, 1965.
- [13] O. M. O’Reilly. The dynamics of rolling discs and sliding discs. *Nonlinear Dynamics*, **10** (1996), 287–305.
- [14] E. J. Routh. *Dynamics of a System of Rigid Bodies (Elementary Part)*. 7th Edition. MacMillan Company, London, 1905. Reprinted by Dover Publications, New York, 1960.
- [15] E. J. Routh. *Dynamics of a System of Rigid Bodies (Advanced Part)*. 6th Edition. MacMillan Company, London, 1905. Reprinted by Dover Publications, New York, 1955.
- [16] A. Vierkandt. Über gleitende und rollende Bewegung. *Monatshefte für Mathematik und Physik*, **3** (1892), 31–54, 97–134.